

Lightning Protection Components (LPC) —

Part 1: Requirements for connection components

ICS 91.120.40

National foreword

This British Standard is the UK implementation of EN 50164-1:2008. It supersedes BS EN 50164-1:2000 which is withdrawn.

The UK participation in its preparation was entrusted to Technical Committee GEL/81, Protection against lightning.

A list of organizations represented on this committee can be obtained on request to its secretary.

This publication does not purport to include all the necessary provisions of a contract. Users are responsible for its correct application.

Compliance with a British Standard cannot confer immunity from legal obligations.

This British Standard was published under the authority of the Standards Policy and Strategy Committee on 30 September 2008

© BSI 2008

ISBN 978 0 580 52980 1

Amendments/corrigenda issued since publication

Date	Comments

English version

**Lightning Protection Components (LPC) -
Part 1: Requirements for connection components**

Composants de protection
contre la foudre (CPF) -
Partie 1: Prescriptions pour
les composants de connexion

Blitzschutzbauteile -
Teil 1: Anforderungen
an Verbindungsbauteile

This European Standard was approved by CENELEC on 2008-04-01. CENELEC members are bound to comply with the CEN/CENELEC Internal Regulations which stipulate the conditions for giving this European Standard the status of a national standard without any alteration.

Up-to-date lists and bibliographical references concerning such national standards may be obtained on application to the Central Secretariat or to any CENELEC member.

This European Standard exists in three official versions (English, French, German). A version in any other language made by translation under the responsibility of a CENELEC member into its own language and notified to the Central Secretariat has the same status as the official versions.

CENELEC members are the national electrotechnical committees of Austria, Belgium, Bulgaria, Cyprus, the Czech Republic, Denmark, Estonia, Finland, France, Germany, Greece, Hungary, Iceland, Ireland, Italy, Latvia, Lithuania, Luxembourg, Malta, the Netherlands, Norway, Poland, Portugal, Romania, Slovakia, Slovenia, Spain, Sweden, Switzerland and the United Kingdom.

CENELEC

European Committee for Electrotechnical Standardization
Comité Européen de Normalisation Electrotechnique
Europäisches Komitee für Elektrotechnische Normung

Central Secretariat: rue de Stassart 35, B - 1050 Brussels

Foreword

This European Standard was prepared by the Technical Committee CENELEC TC 81X, Lightning protection.

It includes the texts of EN 50164-1:1999 + A1:2006 and a draft amendment (prA2) which was submitted to the Unique Acceptance Procedure. The combined texts were approved by CENELEC as EN 50164-1 on 2008-04-01.

This European Standard supersedes EN 50164-1:1999 + A1:2006.

The following dates were fixed:

- latest date by which the EN has to be implemented at national level by publication of an identical national standard or by endorsement (dop) 2009-04-01
- latest date by which the national standards conflicting with the EN have to be withdrawn (dow) 2011-04-01

EN 50164 is a family standard and consists of the following parts under the generic title "*Lightning Protection Components (LPC)*":

- Part 1 Requirements for connection components
- Part 2 Requirements for conductors and earth electrodes
- Part 3 Requirements for isolating spark gaps
- Part 4 Requirements for conductor fasteners
- Part 5 1) Requirements for earth electrode inspection housings and earth electrode seals
- Part 6 1) Requirements for lightning strike counters
- Part 7 Requirements for earthing enhancing compounds

1) In preparation.

Contents

1	Scope	4
2	Normative references	4
3	Definitions	4
4	Classification	5
4.1	According to its capability to withstand lightning current.....	5
4.2	According to its installation.....	5
5	Requirements	5
5.1	General.....	5
5.2	Installation instructions.....	5
5.3	Lightning current carrying capability.....	5
5.4	Screwed clamping connection.....	6
5.5	Dismantling of test joints.....	6
5.6	Damage to conductors and metal installations.....	6
5.7	Safe connection.....	6
5.8	Marking.....	6
5.9	Terminals of bonding bars.....	6
6	Tests	7
6.1	General conditions for tests.....	7
6.2	Test preparation.....	7
6.3	Electrical test.....	8
6.4	Marking test.....	8
7	Electromagnetic compatibility (EMC)	8
8	Structure and content of the test report	8
8.1	Report identification.....	9
8.2	Specimen description.....	9
8.3	Conductor.....	9
8.4	Standards and references.....	9
8.5	Test procedure.....	9
8.6	Testing equipment description.....	10
8.7	Measuring instruments description.....	10
8.8	Results and parameters recorded.....	10
8.9	Statement of pass/fail.....	10
	Annex A (informative) Typical arrangements for various LPC's	14
	Annex B (normative) Conditioning/ageing for connection components	15
	Annex C (informative) Rationale to reduce the number of tests	16
	Tables	
	Table 1 – Lightning impulse current [I_{imp}] parameters.....	8
	Figures	
	Figure 1 – Basic arrangement of specimen with cross connection component.....	11
	Figure 2 – Basic arrangement of specimen with parallel connection component.....	11
	Figure 3 – Basic arrangement of specimen with bridging component.....	12
	Figure 4 – Basic arrangement of specimen with equipotential bonding bar.....	13

1 Scope

This European Standard specifies the requirements and tests for metallic connection components that form part of a Lightning Protection System (LPS). Typically these can be connectors, bonding and bridging components, expansion pieces and test joints.

2 Normative references

The following referenced documents are indispensable for the application of this document. For dated references, only the edition cited applies. For undated references, the latest edition of the referenced document (including any amendments) applies.

EN 60068-2-52	1996	Environmental testing - Part 2: Tests -Test Kb: Salt mist, cyclic (sodium chloride solution) (IEC 60068-2-52:1996)
EN 62305-1		Protection against lightning - Part 1: General principles (IEC 62305-1)
EN 62305-3		Protection against lightning - Part 3: Physical damage to structures and life hazards (IEC 62305-3, mod.)
EN 62305-4		Protection against lightning - Part 4: Electrical and electronic systems within structures (IEC 62305-4)
EN ISO 6988	1994	Metallic and other non-organic coatings - Sulphur dioxide test with general condensation of moisture (ISO 6988:1985)
ISO 6957	1988	Copper alloys - Ammonia test for stress corrosion resistance

3 Definitions

For the purpose of this European Standard, the following definitions apply:

3.1

connection component

component for the connection of conductors to each other or to metal installations. This also includes bridging component and expansion piece

3.2

metal installation

extended metal items in the structure to be protected which may form a path for lightning current, such as pipes, staircases, elevator guide rails, ventilation, heating and air conditioning ducts, and interconnected reinforcing steel

3.3

bridging component

connection component for the connection of metal installations

3.4

expansion piece

connection component designed to compensate for changes in length in conductors and/or metal installations caused by temperature changes

3.5

connector

connection component to interconnect two or more conductors

3.6**clamp**

connection component for the connection of conductors to metal installations

3.7**pipe clamp**

clamp for the connection of conductors to metal pipes

3.8**test joint**

a joint which is designed and situated to facilitate electrical testing and measurement of LPS

3.9**connection range**

the range minimum to maximum on which a specific connection component is designed to be used

3.10**bonding bar**

metal bar on which metal installations, external conductive parts, electric power and telecommunication lines, and other cables can be connected to an LPS

4 Classification**4.1 According to its capability to withstand lightning current**

- class H for heavy duty;
- class N for normal duty.

4.2 According to its installation

- above ground or buried in ground;
- buried in concrete.

5 Requirements**5.1 General**

Connection components shall be designed in such a manner that when they are installed in accordance with the manufacturer's instructions their performance shall be reliable, stable and safe to persons and surrounding equipment.

5.2 Installation instructions

The manufacturer of the connection components shall provide adequate instructions in his literature to ensure that the installer of the connection components can select and install them in a suitable and safe manner.

Compliance is checked by inspection.

5.3 Lightning current carrying capability

Connection components shall have sufficient lightning current carrying capability.

Compliance is checked in accordance with 6.3 following the manufacturer's declaration for the class H or N of the connection components in accordance with 4.1.

5.4 Screwed clamping connection

Where screws and/or nuts are used as the clamping connection, the design shall be such that the conductor and/or the metal installation is always securely fastened by the screw and/or nut application.

Compliance is checked by inspection and in accordance with 6.3.

5.5 Dismantling of test joints

It shall be possible to dismantle the test joints after lightning current stress.

Compliance is checked in accordance with 6.3.

5.6 Damage to conductors and metal installations

Connection components shall be so designed that they connect the conductors and/or the metal installations without undue damage to the conductors, the metal installations and/or the connection components.

Compliance is checked by inspection.

5.7 Safe connection

Connection components shall guarantee safe connection within the connection range declared by the manufacturer.

Compliance is checked in accordance with 6.3.

5.8 Marking

The connection components shall be marked at least with the following:

- a) manufacturer's or responsible vendor's name or trade mark;
- b) identifying symbol;
- c) the classification, i.e. class N or H.

Where this proves to be impractical the marking in accordance with b) and c) may be given on the smallest packing unit.

The marking shall be durable and legible.

NOTE Marking may be applied for example by moulding, pressing, engraving, printing adhesive labels, or water slide transfers.

Compliance is checked in accordance with 6.4.

5.9 Terminals of bonding bars

Terminals of bonding bars used for lightning protection installations shall have connection sizes equal to or greater than 16 mm².

6 Tests

6.1 General conditions for tests

6.1.1 The tests in accordance with this standard are type tests.

6.1.2 Unless otherwise specified, tests are carried out with the specimens assembled and installed as in normal use according to the manufacturer's or supplier's installation instructions with the recommended conductor materials, sizes and the tightening torques. If the connection component is suitable for various conductors' materials, then it shall be tested on each material combination.

6.1.3 All tests are carried out on new specimens.

6.1.4 Unless otherwise specified, three specimens are subjected to the tests and the requirements are satisfied if all the tests are met.

If only one of the specimens does not satisfy a test due to an assembly or a manufacturing fault, that test and any preceding one which may have influenced the results of the test shall be repeated and also the tests which follow shall be carried out in the required sequence on another full set of specimens, all of which shall comply with the requirements.

NOTE The applicant, when submitting a set of specimens, may also submit an additional set of specimens which may be necessary should one specimen fail. The testing station will then, without further request, test the additional set of specimens and will reject only if a further failure occurs. If the additional set of specimens is not submitted at the same time, the failure of one specimen will entail rejection.

6.1.5 The test shall be carried out in the order given after conditioning/ ageing the arrangement of the specimen in accordance with 6.2.2.

6.2 Test preparation

6.2.1 Arrangement of the specimen

If not otherwise specified by the manufacturer the conductors and the specimens shall be cleaned by using a suitable degreasing agent followed by cleaning in demineralising water and drying. They shall then be assembled in accordance with the manufacturer's instructions, e.g. with the recommended conductors and the tightening torques.

If a connection component is used in more than one arrangement (see Annex A) as recommended by the manufacturer's installation instructions, then it shall be tested for each one of these arrangements.

The basic arrangement of the specimen with cross connection component, parallel connection component, bridging component and equipotential bonding bar is shown in Figures 1, 2, 3 and 4 respectively. Terminals of bonding bars are only tested if the connection size is equal to or greater than 16 mm². The test is carried out using the smallest conductor size within the range of the terminal with a minimum of 16mm² conductor. Typical arrangements for various LPC's are shown in Annex A.

NOTE It is permitted to test more than one arrangement of the specimen in series simultaneously. The actual number of the specimens to be tested is arbitrary and is dependent on the electrical test equipment.

6.2.2 Conditioning/ageing

Following the manufacturer's declaration in accordance with 4.2 the arrangement of the specimen shall be subjected to a conditioning/ageing consisting of a salt mist treatment as specified in B.1 followed by a humid sulphurous atmosphere treatment as specified in B.2, and an additional ammonia atmosphere treatment for specimens made of copper alloy with a copper content less than 80 % as specified in B.3.

After the treatment the arrangement is fixed on an insulated plate taking care to avoid any damage to the specimen due to handling. The minimum distance between the specimen, conductors and the insulating plate shall be 20 mm.

NOTE 1 This treatment is not necessary for connection components designed to be embedded exclusively in concrete.

NOTE 2 Bonding bars only for indoor applications are tested without conditioning/ageing.

6.3 Electrical test

After 6.2.2 and without cleaning the arrangement, the specimen shall be stressed three times by a test current as given in Table 1. The time interval between individual shots shall allow the arrangement of the specimen to cool down to approximately ambient temperature.

Table 1 – Lightning impulse current [I_{imp}] parameters

Classification	I_{imp} $\pm 10\%$ [kA]	W/R $\pm 35\%$ [kJ/ Ω]	T_1 [μ s]	t_d [ms]
H	100	2 500	≤ 50	≤ 2
N	50	630	≤ 50	≤ 2

NOTE These parameters are derived from EN 61643-11, Low-voltage surge protective devices – Part 11: Surge protective devices connected to the low-voltage systems – Requirements and tests.

The test current is defined by its current peak value I_{max} , the specific energy W/R and its duration t_d .

NOTE The parameters specified in Table 1 can typically be achieved by an exponential decaying current with T_2 in the range of 350 μ s according to EN 62305-1.

The connection component is deemed to have passed the test if:

- the contact resistance, measured with a source of at least 10 A, as close as possible to the connection component, is equal to or less than 1 m Ω but in the special case of stainless steel a value of 2,5 m Ω ;
- it does not exhibit any crack to normal or corrected vision without magnification nor does it have any loose parts or deformation impairing its normal use;
- for screwed clamping connections the loosening torque is greater than 0,25 and less than 1,5 times the tightening torque. In the case of connectors with more than one screw, only the loosening torque of the first screw is relevant to this test.

6.4 Marking test

The marking is checked by inspection and by rubbing it by hand for 15 s with a piece of cloth soaked with water and again for 15 s with a piece of cloth soaked with white spirit.

NOTE Marking made by moulding, pressing or engraving is not subjected to this test.

After the test the marking shall be legible.

7 Electromagnetic compatibility (EMC)

Products covered by this standard are, in normal use, passive in respect of electromagnetic influences (emission and immunity).

8 Structure and content of the test report

The purpose of this instruction is to provide general requirements for laboratory test reports. This document is intended to promote clear, complete reporting procedures for laboratories submitting test reports.

The results of each test carried out by the laboratory shall be reported accurately, clearly, unambiguously and objectively, in accordance with any instructions in the test methods. The results shall be reported in a test report and shall include all the information necessary for the interpretation of the test results and all information required by the method used.

Particular care and attention shall be paid to the arrangement of the report, especially with regard to presentation of the test data and ease of assimilation by the reader. The format shall be carefully and specifically designed for each type of test carried out, but the headings shall be standardized as indicated herein.

The structure of each report shall include at least information according to 8.1 to 8.9.

8.1 Report identification

- 8.1.1 A title or subject of the report
- 8.1.2 Name, address and telephone number of the test laboratory
- 8.1.3 Name, address and telephone number of the sub test laboratory where the test was carried out if different from company which has been assigned to perform the test
- 8.1.4 Unique identification number (or serial number) of the test report
- 8.1.5 Name and address of the vendor
- 8.1.6 Report shall be paginated and the total number of pages indicated
- 8.1.7 Date of issue of report
- 8.1.8 Date(s) of performance of test(s)
- 8.1.9 Signature and title, or an equivalent identification of the person(s) authorized to sign for the testing laboratory for the content of the report
- 8.1.10 Signature and title of person(s) conducting the test

8.1.1 Specimen description

- 8.2.1 Sample description
- 8.2.2 Detailed description and unambiguous identification of the test sample and/or test assembly
- 8.2.3 Characterization and condition of the test sample and/or test assembly
- 8.2.4 Sampling procedure, where relevant
- 8.2.5 Date of receipt of test items
- 8.2.6 Photographs, drawings or any other visual documentation, if available

8.2 Conductor

- 8.3.1 Conductor material
- 8.3.2 Nominal cross-section area dimensions and shape. It is recommended that the actual cross-sectional area should also be given

8.3 Standards and references

- 8.4.1 Identification of the test standard used and the date of issue of the standard
- 8.4.2 Other relevant documentation with the documentation date

8.4 Test procedure

- 8.5.1 Description of the test procedure
- 8.5.2 Justification for any deviations from, additions to or exclusions from the referenced standard
- 8.5.3 Any other information relevant to a specific test such as environmental conditions
- 8.5.4 Configuration of testing assembly

8.5.5 Location of the arrangement in the testing area and measuring techniques

8.5 Testing equipment description

8.6.1 Description of equipment used for every test conducted i.e. generator, conditioning/ageing device

8.6 Measuring instruments description

8.7.1 Characteristics and calibration date of all instruments used for measuring the values specified in the standard i.e. radius gauge shunts, tensile testing machine, extensometer, ohmmeter, torque meter, thickness calliper gauge etc.

8.7 Results and parameters recorded

The measured, observed or derived results shall be clearly identified at least for

8.8.1 Current

8.8.2 Charge

8.8.3 Specific energy

8.8.4 Duration

8.8.5 Ohmic resistance

8.8.6 Tightening torque

8.8.7 Loosening torque

The above shall be presented by tables, graphs, drawings, photographs or other documentation of visual observations as appropriate.

8.8 Statement of pass/fail

A statement of pass/fail identifying the part of the test for which the specimen has failed and also a description of the failure.

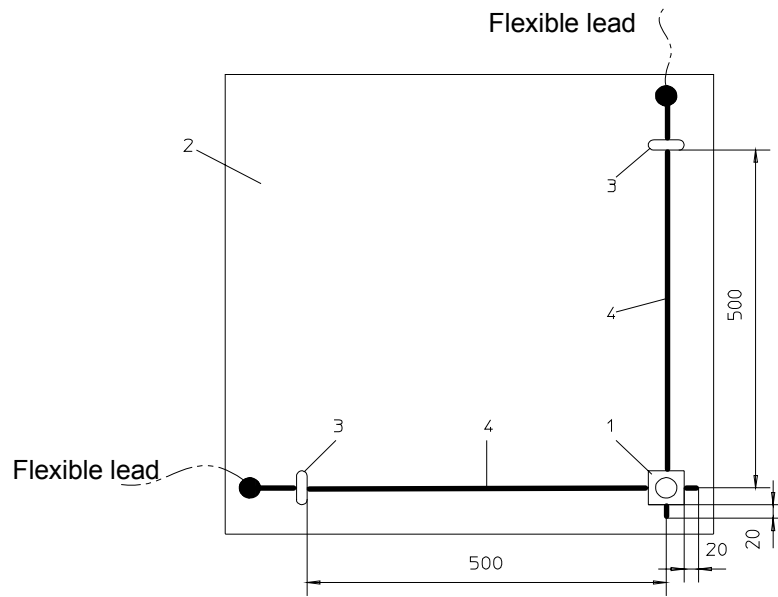

- 1 Cross connection component
- 2 Plate made of insulating material
- 3 Rigid fastener
- 4 Conductor and/or metal installation

Figure 1 – Basic arrangement of specimen with cross connection component

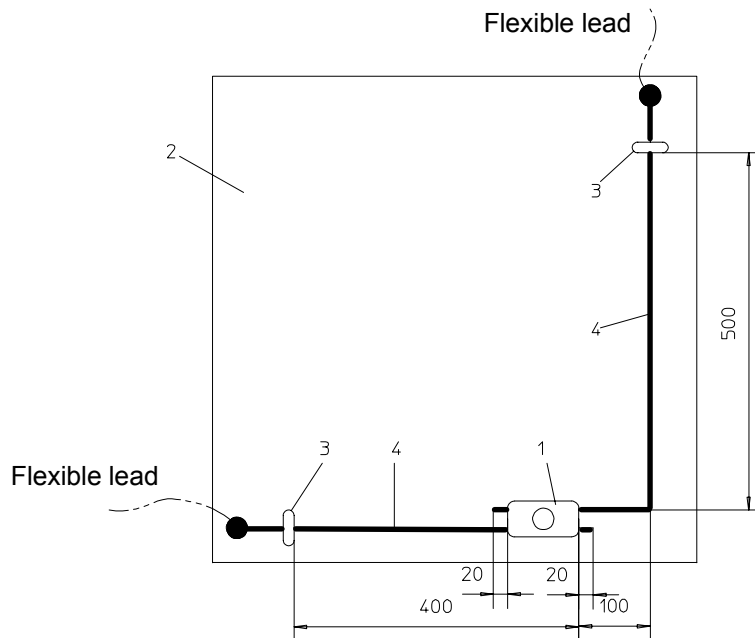

- 1 Parallel connection component
- 2 Plate made of insulating material
- 3 Rigid fastener
- 4 Conductor and/or metal installation

Figure 2 – Basic arrangement of specimen with parallel connection component

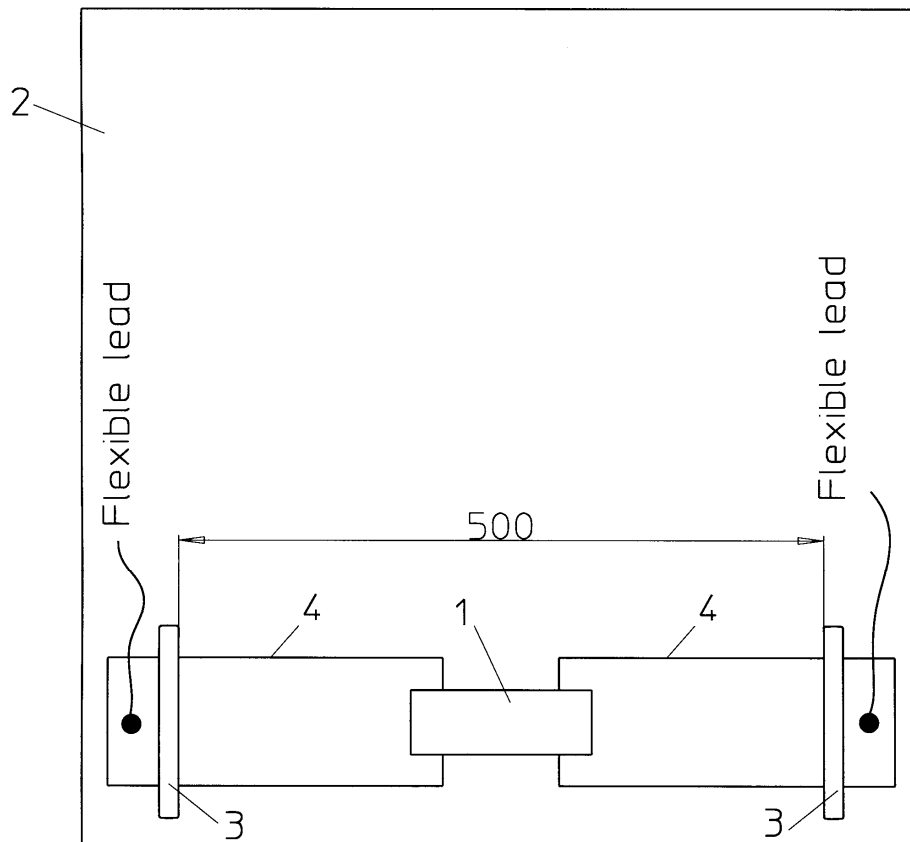

Key

- 1 Bridging component
- 2 Plate made of insulating material
- 3 Rigid fastener
- 4 Metal installation

Figure 3 – Basic arrangement of specimen with bridging component

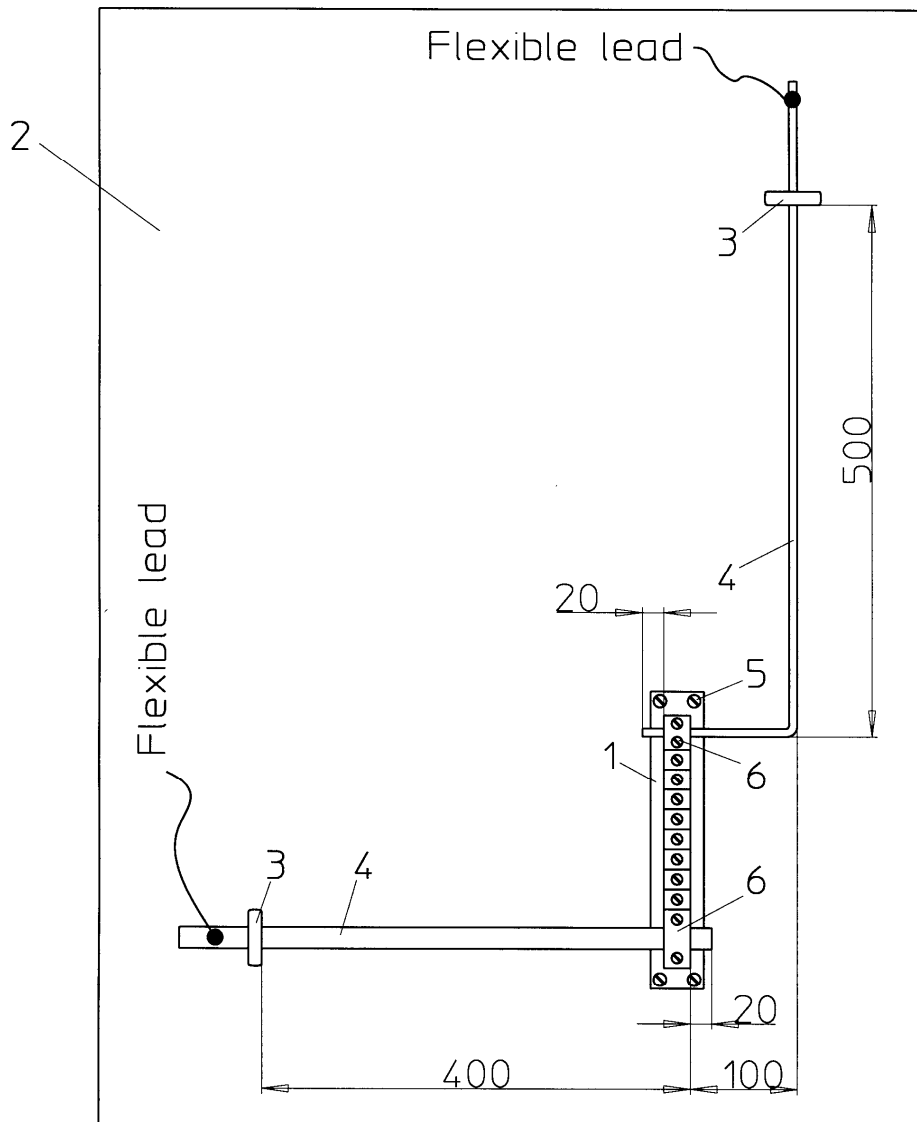

Key

- 1 Equipotential bonding bar
- 2 Plate made of insulating material
- 3 Rigid fastener
- 4 Conductor
- 5 Fixing points of equipotential bonding bar
- 6 Connection to be tested

Figure 4 – Basic arrangement of specimen with equipotential bonding bar

Annex A
 (informative)

Typical arrangements for various LPC's

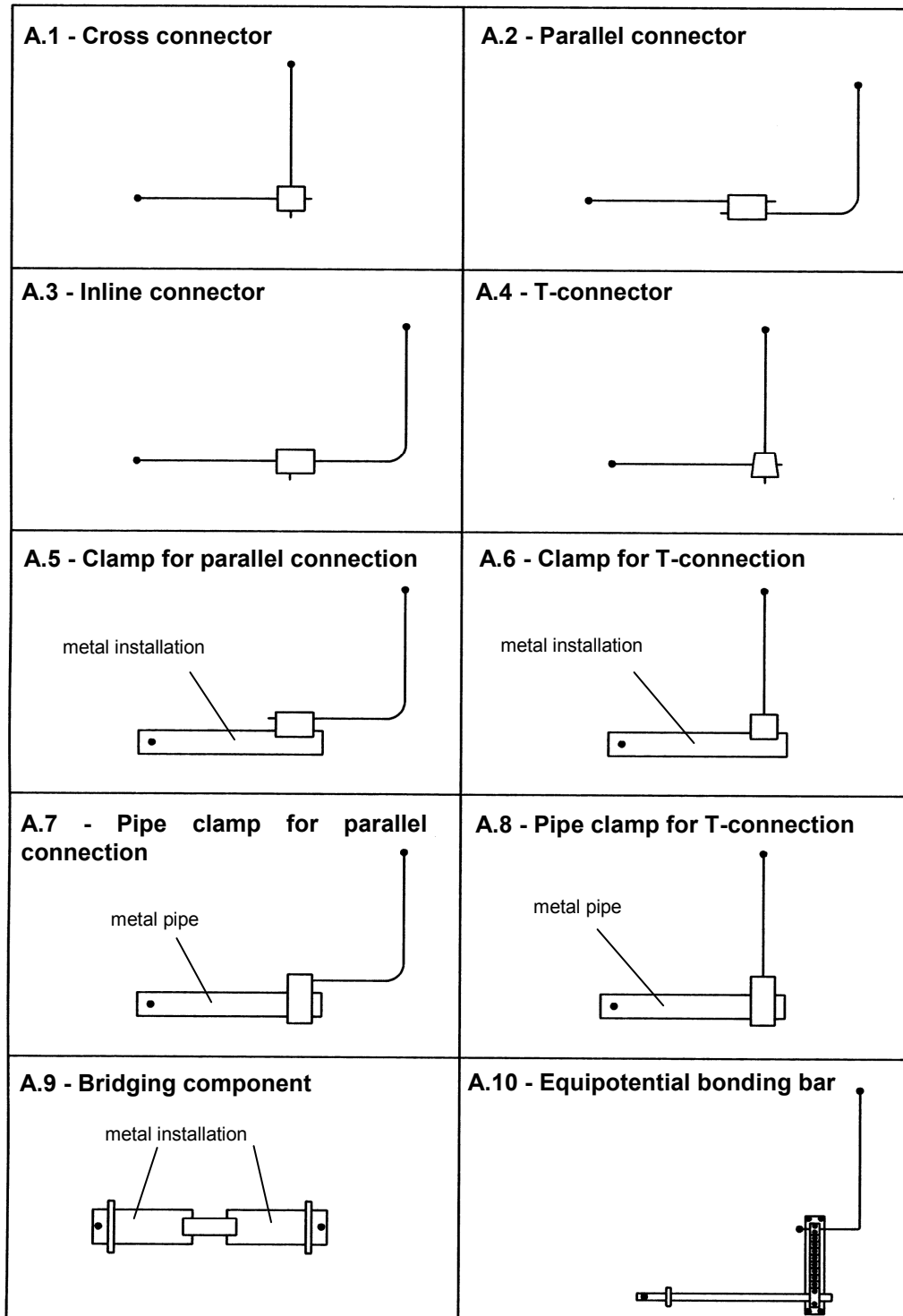

- NOTE 1 A.1, A.4, A.6 and A.8 - for more information see Figure 1.
 NOTE 2 A.2, A.3, A.5 and A.7 - for more information see Figure 2.
 NOTE 3 A.9 - for more information see Figure 3.
 NOTE 4 A.10 - for more information see Figure 4.

Annex B (normative)

Conditioning/ageing for connection components

B.1 Salt mist treatment

Salt mist treatment according to EN 60068-2-52:1996 except for Clauses 7, 10 and 11 which are not applicable.

The test is carried out using severity (2).

NOTE If the salt mist chamber can maintain the temperature conditions as specified in 9.3 of EN 60068-2-52:1996 and a relative humidity of not less than 90 % then the specimen may remain in it for the humidity storage period.

B.2 Humid sulphurous atmosphere treatment

Humid sulphurous atmosphere treatment according to EN ISO 6988:1994 with seven cycles with a concentration of sulphur dioxide of 667 ppm (in volume) \pm 25 ppm, except for Clauses 9 and 10 which are not applicable.

Each cycle which has duration of 24 h is composed of a heating period of 8 h at a temperature of $40\text{ }^{\circ}\text{C} \pm 3\text{ }^{\circ}\text{C}$ in the humid saturated atmosphere which is followed by a rest period of 16 h. After that, the humid sulphurous atmosphere is replaced.

NOTE If the test chamber maintains the temperature conditions as specified in 6.5.2 of EN ISO 6988:1994 then the specimen may remain in it for the storage period.

B.3 Ammonia atmosphere treatment

Ammonia atmosphere treatment according to ISO 6957:1988 for a moderate atmosphere with the pH value 10 except for 8.4 and Clause 9, which are not applicable.

Annex C
(informative)

Rationale to reduce the number of tests

C.1 Arrangement criterion

A connection component designed for use in various arrangements does not need to be tested in each of these individual arrangements as shown in Annex A.

The following identifies what arrangements are covered for this purpose:

- arrangement A.4 covers arrangement A.1.

C.2 Design criterion

Under consideration.

www.TeraStandard.com

www.TeraStandard.com

British Standards Institution (BSI)

BSI is the independent national body responsible for preparing British Standards. It presents the UK view on standards in Europe and at the international level. It is incorporated by Royal Charter.

Revisions

British Standards are updated by amendment or revision. Users of British Standards should make sure that they possess the latest amendments or editions.

It is the constant aim of BSI to improve the quality of our products and services. We would be grateful if anyone finding an inaccuracy or ambiguity while using this British Standard would inform the Secretary of the technical committee responsible, the identity of which can be found on the inside front cover.
Tel: +44 (0)20 8996 9000 Fax: +44 (0)20 8996 7400

BSI offers members an individual updating service called PLUS which ensures that subscribers automatically receive the latest editions of standards.

Buying standards

Orders for all BSI, international and foreign standards publications should be addressed to Customer Services.

Tel: +44 (0)20 8996 9001 Fax: +44 (0)20 8996 7001

Email: orders@bsigroup.com

You may also buy directly using a debit/credit card from the BSI Shop on the Website <http://www.bsigroup.com/shop>.

In response to orders for international standards, it is BSI policy to supply the BSI implementation of those that have been published as British Standards, unless otherwise requested.

Information on standards

BSI provides a wide range of information on national, European and international standards through its Library and its Technical Help to Exporters Service. Various BSI electronic information services are also available which give details on all its products and services. Contact the Information Centre.

Tel: +44 (0)20 8996 7111 Fax: +44 (0)20 8996 7048

Email: info@bsigroup.com

Subscribing members of BSI are kept up to date with standards developments and receive substantial discounts on the purchase price of standards. For details of these and other benefits contact Membership Administration.

Tel: +44 (0)20 8996 7002 Fax: +44 (0)20 8996 7001

Email: membership@bsigroup.com

Information regarding online access to British Standards via British Standards Online can be found at <http://www.bsigroup.com/BSOL>.

Further information about BSI is available on the BSI website at <http://www.bsigroup.com>.

Copyright

Copyright subsists in all BSI publications. BSI also holds the copyright, in the UK, of the publications of the international standardization bodies. Except as permitted under the Copyright, Designs and Patents Act 1988 no extract may be reproduced, stored in a retrieval system or transmitted in any form or by any means – electronic, photocopying, recording or otherwise – without prior written permission from BSI.

This does not preclude the free use, in the course of implementing the standard, of necessary details such as symbols, and size, type or grade designations. If these details are to be used for any other purpose than implementation then the prior written permission of BSI must be obtained.

Details and advice can be obtained from the Copyright & Licensing Manager.

Tel: +44 (0)20 8996 7070 Email: copyright@bsigroup.com