

Standard Recommended Practice

External Cathodic Protection of On-Grade Carbon Steel Storage Tank Bottoms

This NACE International standard represents a consensus of those individual members who have reviewed this document, its scope, and provisions. Its acceptance does not in any respect preclude anyone, whether he has adopted the standard or not, from manufacturing, marketing, purchasing, or using products, processes, or procedures not in conformance with this standard. Nothing contained in this NACE International standard is to be construed as granting any right, by implication or otherwise, to manufacture, sell, or use in connection with any method, apparatus, or product covered by Letters Patent, or as indemnifying or protecting anyone against liability for infringement of Letters Patent. This standard represents minimum requirements and should in no way be interpreted as a restriction on the use of better procedures or materials. Neither is this standard intended to apply in all cases relating to the subject. Unpredictable circumstances may negate the usefulness of this standard in specific instances. NACE International assumes no responsibility for the interpretation or use of this standard by other parties and accepts responsibility for only those official NACE International interpretations issued by NACE International in accordance with its governing procedures and policies which preclude the issuance of interpretations by individual volunteers.

Users of this NACE International standard are responsible for reviewing appropriate health, safety, environmental, and regulatory documents and for determining their applicability in relation to this standard prior to its use. This NACE International standard may not necessarily address all potential health and safety problems or environmental hazards associated with the use of materials, equipment, and/or operations detailed or referred to within this standard. Users of this NACE International standard are also responsible for establishing appropriate health, safety, and environmental protection practices, in consultation with appropriate regulatory authorities if necessary, to achieve compliance with any existing applicable regulatory requirements prior to the use of this standard.

CAUTIONARY NOTICE: NACE International standards are subject to periodic review, and may be revised or withdrawn at any time without prior notice. NACE International requires that action be taken to reaffirm, revise, or withdraw this standard no later than five years from the date of initial publication. The user is cautioned to obtain the latest edition. Purchasers of NACE International standards may receive current information on all standards and other NACE International publications by contacting the NACE International Membership Services Department, 1440 South Creek Dr, Houston, Texas 77084-4906 (telephone +1[281]228-6200).

Revised 2001-06-15
Approved October 1993
NACE International
1440 South Creek Drive
Houston, Texas 77084-4906
+1 281/228-6200

ISBN 1-57590-014-9
©2001, NACE International

Foreword

It is extremely important to maintain the integrity of on-grade carbon steel storage tanks for both economic and environmental reasons. The proper design, installation, and maintenance of cathodic protection (CP) systems can help maintain the integrity and increase the useful service life of on-grade carbon steel storage tanks.

The purpose of this standard recommended practice is to outline practices and procedures for providing cathodic protection to the soil side of bottoms of on-grade carbon steel storage tanks that are in contact with an electrolyte. Recommendations for both galvanic anode systems and impressed current systems are included. Design criteria for the upgrade of existing tanks as well as for newly constructed tanks are included. This standard is intended for use by personnel planning to install new on-grade carbon steel storage tanks, upgrade cathodic protection on existing storage tanks, or install new cathodic protection on existing storage tanks.

This NACE standard was originally prepared by Task Group T-10A-20, a component of NACE Unit Committee T-10A on Cathodic Protection, in 1993. It was technically revised by Task Group 013 in 2001. Task Group 013 is administered by Specific Technology Group (STG) 35 on Pipelines, Tanks, and Well Casings and sponsored by STGs 03 on Protective Coatings and Linings—Immersion/Buried and STG 05 on Cathodic/Anodic Protection. This standard is issued by NACE International under the auspices of STG 35 on Pipelines, Tanks, and Well Casings.

In NACE standards, the terms *shall*, *must*, *should*, and *may* are used in accordance with the definitions of these terms in the *NACE Publications Style Manual*, 4th ed., Paragraph 7.4.1.9. *Shall* and *must* are used to state mandatory requirements. The term *should* is used to state something good and is recommended but is not mandatory. The term *may* is used to state something considered optional.

**NACE International
Standard
Recommended Practice**

**External Cathodic Protection of On-Grade Carbon Steel
Storage Tank Bottoms**

Contents

1. General 1

2. Definitions 1

3. Preliminary Evaluation and Determination of the Need for Cathodic Protection..... 2

4. Criteria for Cathodic Protection..... 5

5. General Considerations for Cathodic Protection Design 7

6. Design Considerations for Impressed Current Cathodic Protection 9

7. Design Considerations for Galvanic Anode Cathodic Protection 11

8. Design Considerations — Cathodic Protection for Tanks with Replacement Bottoms or
Release Prevention Barriers 12

9. Installation Considerations..... 15

10. Energizing and Testing 17

11. Operation and Maintenance of Cathodic Protection Systems 18

12. Recordkeeping 19

References..... 19

Bibliography 20

Figures

Figure 1: Soil Resistivity Testing (Four-Pin Method)..... 3

Figure 2: Temporary Groundbed for Current Requirement Testing 5

Figure 3: Stray Current Corrosion..... 6

Figure 4: Vertically Drilled Anode CP System..... 9

Figure 5: Angled Anode Cathodic Protection System 10

Figure 6: Deep Anode Groundbed..... 10

Figure 7: Horizontally Installed Anode Groundbed 10

Figure 8: Typical Double-Bottom Cathodic Protection Layout (Impressed or Sacrificial) 13

Figure 9: Typical Double-Bottom Galvanic Anode Design..... 14

Figure 10: Typical New Tank or Double-Bottom Impressed Current Anode Design 14

Figure 11: Perforated Pipe Installed for Reference Electrode 16

Section 1: General

1.1 This standard presents guidelines for the design, installation, and maintenance of cathodic protection for the exterior bottoms of on-grade carbon steel storage tanks. Cathodic protection can be installed to protect new or existing tanks, but cannot protect carbon steel surfaces that are not in contact with an electrolyte.

1.2 This standard is applicable to welded, bolted, and riveted carbon steel tanks that are either field- or shop-fabricated.

1.3 It is understood in this standard that cathodic protection may be used alone or in conjunction with protective coatings.

1.4 All cathodic protection systems should be installed with the intent of conducting uninterrupted, safe operations. When cathodic protection is applied, it should be operated continuously to maintain polarization.

1.5 The criteria for cathodic protection are based on current industry standards.

1.6 Corrosion control must be a consideration during the design of on-grade carbon steel storage tanks.

Section 2: Definitions

Amphoteric Metal: A metal that is susceptible to corrosion in both acid and alkaline environments.

Anode: The electrode of an electrochemical cell at which oxidation occurs. Electrons flow away from the anode in the external circuit. Corrosion usually occurs and metal ions enter the solution at the anode.

Backfill: Material placed in a hole to fill the space around the anodes, vent pipe, and buried components of a cathodic protection system.

Cathode: The electrode of an electrochemical cell at which reduction is the principal reaction. Electrons flow toward the cathode in the external circuit.

Cathodic Protection (CP): A technique to reduce the corrosion of a metal surface by making that surface the cathode of an electrochemical cell.

Cell: See *Electrochemical Cell*.

Current Density: The current to or from a unit area of an electrode surface.

Deep Groundbed: One or more anodes installed vertically at a nominal depth of 15 m (50 ft) or more below the earth's surface in a drilled hole for the purpose of supplying cathodic protection.

Differential Aeration Cell: An electrochemical cell, the electromotive force of which is due to a difference in air (oxygen) concentration at one electrode as compared with that at another electrode of the same material.

Electrical Isolation: The condition of being electrically separated from other metallic structures or the environment.

Electrochemical Cell: A system consisting of an anode and a cathode immersed in an electrolyte so as to create an electrical circuit. The anode and cathode may be different metals or dissimilar areas on the same metal surface.

Electrolyte: A chemical substance containing ions that migrate in an electric field.

External Circuit: The wires, connectors, measuring devices, current sources, etc., that are used to bring about or measure the desired electrical conditions within an electrochemical cell. It is this portion of the cell through which electrons travel.

Foreign Structure: Any metallic structure that is not intended as a part of a system under cathodic protection.

Galvanic Anode: A metal that provides sacrificial protection to another metal that is more noble when electrically coupled in an electrolyte. This type of anode is the electron source in one type of cathodic protection.

Groundbed: One or more anodes installed below the earth's surface for the purpose of supplying cathodic protection. For the purposes of this standard, a groundbed is defined as a single anode or group of anodes installed in the electrolyte for the purposes of discharging direct current to the protected structure.

Impressed Current: An electric current supplied by a device employing a power source that is external to the electrode system. (An example is direct current for cathodic protection).

On-Grade Storage Tank: A tank constructed on sand or earthen pads, concrete ringwalls, or concrete pads.

RP0193-2001

Oxidation: (1) Loss of electrons by a constituent of a chemical reaction. (2) Corrosion of a metal that is exposed to an oxidizing gas at elevated temperatures.

Piping: For the purposes of this standard, this term refers to all piping associated with the transfer of products in and out of storage tanks.

Reduction: Gain of electrons by a constituent of a chemical reaction.

Reference Electrode: An electrode whose open-circuit potential is constant under similar conditions of measurement, which is used for measuring the relative potentials of other electrodes.

Stray-Current Corrosion: Corrosion resulting from current through paths other than the intended circuit, e.g., by any extraneous current in the earth.

Section 3: Preliminary Evaluation and Determination of the Need for Cathodic Protection

3.1 This section outlines the information that should be considered prior to designing a cathodic protection system to protect on-grade carbon steel storage tank bottoms in contact with an electrolyte.

3.2 Site Assessment Information

3.2.1 Prior to designing a cathodic protection system, the following information should be obtained:

- (a) Tank, piping, and grounding construction drawings, including dimensions, etc.
- (b) Site plan and layout
- (c) Date of construction
- (d) Material specifications and manufacturer
- (e) Joint construction (i.e., welded, riveted, etc.)
- (f) Coating specifications
- (g) Existing or proposed cathodic protection systems in the area
- (h) Location of electric power sources
- (i) Electrochemical properties of the tank bedding or padding material
- (j) History of the tank foundation (i.e., whether the tank has been jacked up/leveled, etc.)
- (k) Unusual environmental conditions
- (l) Operating history of the tank, including leak information (internal and external)
- (m) Maintenance history of the tank
- (n) Containment membranes/impervious linings
- (o) Secondary bottoms
- (p) Water table and site drainage information
- (q) Liquid levels maintained in the tank
- (r) Nearby foreign structures
- (s) Type of liquid stored
- (t) Operating temperature
- (u) Electrical grounding

3.3 Predesign Site Appraisal

3.3.1 Determining the Extent of Corrosion on Existing Systems

3.3.1.1 Information regarding the degree of tank-bottom corrosion is useful because considerable bottom damage may require extensive repairs or replacement prior to the installation of cathodic protection.

3.3.1.2 Field procedures for determining the extent of existing corrosion may include:

- (a) Visual inspection
- (b) Tank bottom plate-thickness measurements (ultrasonic testing, coupon analysis, etc.)
- (c) Estimation of general corrosion rates through the use of electrochemical procedures
- (d) Determination of the magnitude and direction of galvanic or stray current transferred to or from the tank through piping and other interconnections
- (e) Determination of soil characteristics including resistivity, pH, chloride ion concentration, sulfide ion concentration, and moisture content
- (f) Estimation of the degree of corrosion deterioration based on comparison with data from similar facilities subjected to similar conditions

3.3.1.3 Foundation characteristics are also important factors in the assessment of the extent of existing corrosion. The pad material of construction, thickness of ringwalls, and water drainage should all be considered.

3.3.1.4 Data pertaining to existing corrosion conditions should be obtained in sufficient quantity to permit reasonable engineering judgments. Statistical procedures should be used in the analysis, if appropriate.

3.3.2 Electrical Isolation

3.3.2.1 Electrical isolation facilities must be compatible with electrical grounding requirements conforming to applicable codes and safety requirements. If the tank bottom is to be cathodically protected, the use of alternative electrical grounding materials, such as galvanized steel and galvanic anodes, should be considered.

3.3.2.2 The designer of a cathodic protection system should consider the possible need for electrical isolation of the tank from piping and other interconnecting structures. Isolation may be necessary for effective cathodic protection or safety considerations.

3.3.2.3 Electrical isolation of interconnecting piping can be accomplished through the use of isolating flanges, dielectric bushings or unions, or other devices specifically designed for this purpose. These devices shall be rated for the proper operating pressure and be compatible with the products being transported.

3.3.2.4 Polarization cells, lightning arresters, grounding cells, and other decoupling devices may be useful in some situations for maintaining isolation under normal operating conditions and providing protection for an isolating device during lightning strikes, power surges, and other abnormal situations.

3.3.2.5 Tests to determine tank electrical characteristics include:

- (a) Tank-to-earth resistance tests
- (b) Tank-to-grounding system resistance and potential tests
- (c) Tank-to-electrolyte potential tests
- (d) Electrical continuity tests for mechanical joints in interconnecting piping systems
- (e) Electrical leakage tests for isolating fittings installed in interconnecting piping and between the tanks and safety ground conductors

3.3.3 Cathodic Protection Type, Current Requirements, and Anode Configuration

3.3.3.1 Soil resistivity tests should be performed in sufficient quantity as to aid in determining the type of cathodic protection (galvanic or impressed current) required and the configuration for the anode system. Figure 1 illustrates the four-pin method of soil resistivity testing.

3.3.3.2 Resistivities can be determined using the four-pin method described in ASTM⁽¹⁾ G 57,¹ with pin spacings corresponding to depths of at least that expected for the anode system, or by using an equivalent testing method (in very dry environments, electromagnetic conductivity testing may be used to measure resistivities).² The resistivity measurements should be obtained in sufficient detail to identify possible variations with respect to depth and location. As a general guideline, resistivity data should be obtained at a minimum of two locations per tank.

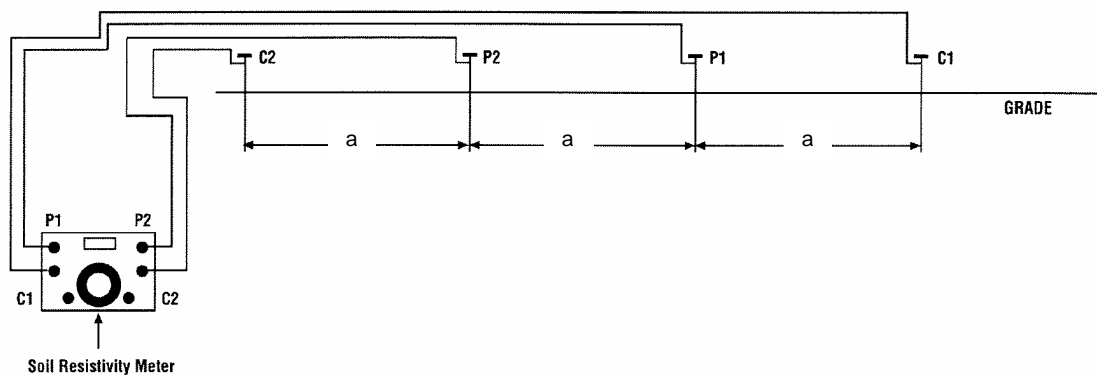

Figure 1: Soil Resistivity Testing (Four-Pin Method)
Note: a = Depth of interest for the soil resistivity measurement.

⁽¹⁾ American Society for Testing and Materials (ASTM), 100 Barr Harbor Dr., West Conshohocken, P.A. 19428.

3.3.3.3 If deep groundbeds are considered, resistivities should be analyzed using procedures described by Barnes³ to determine conditions on a layer-by-layer basis. On-site resistivity data can be supplemented with geological data including subsurface stratigraphy, hydrology, and lithology. Sources for geological information include water well drillers, oil and gas production companies, the U.S. Geological Survey Office,⁽²⁾ and other regulatory agencies.

3.3.3.4 Cathodic protection current requirements can be estimated using test anode arrays simulating the type of groundbed planned. Test currents can be applied using suitable sources of direct current. Test groundbeds can include driven rods, anode systems for adjacent cathodic protection installations, or other temporary structures that are electrically separated from the tank being tested. Small-diameter anode test wells may be appropriate and should be considered if extensive use of deep anode groundbeds is being considered. Figure 2 illustrates a temporary groundbed for current requirement testing.

3.3.4 Stray Currents

3.3.4.1 The presence of stray earth currents may result in cathodic protection current requirements that are greater than those required under natural conditions. Possible sources of stray current include DC-operated rail systems and mining operations, other cathodic protection systems, welding equipment, and high-voltage direct current (HVDC) transmission systems.

3.3.4.1.1 Field tests to determine whether stray currents are a concern include those that provide tank-to-electrolyte and structure-to-electrolyte potential measurements on adjacent structures, earth gradient measurements, and current flow measurements on tank piping and safety grounding conductors.

3.3.4.1.2 Possible interference effects caused by adjacent cathodic protection systems should be determined by interrupting the current output using a known timing cycle. Structure-to-electrolyte potentials and other parameters should be monitored over a minimum 24-hour period in areas where dynamic stray currents or transient effects are expected to be a concern. Recording instruments can be used for this purpose. Figure 3 illustrates stray current corrosion.

3.3.4.1.3 Cathodic protection designs should incorporate every practical effort to minimize electrical interference on structures not included in the protection system. Predesign test results can be analyzed to determine the possible need for stray-current control provisions in the cathodic protection system.

⁽²⁾ U.S. Geological Survey Office, P.O. Box 25046. Federal Center, Denver, CO 80225.

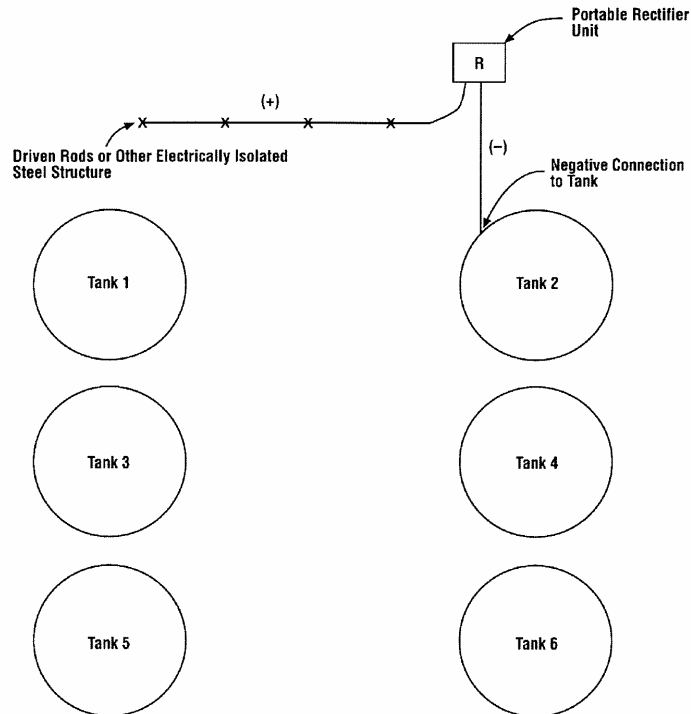

Figure 2: Temporary Groundbed for Current Requirement Testing

Section 4: Criteria for Cathodic Protection

4.1 This section lists criteria for cathodic protection that, if complied with either separately or collectively, indicate that cathodic protection of an on-grade carbon steel storage tank bottom has been achieved.

4.2 General

4.2.1 The objective of using cathodic protection is to control the corrosion of an on-grade carbon steel storage tank bottom in contact with an electrolyte. The selection of a particular criterion for achieving this objective depends, in part, on prior experience with

similar tank bottoms and environments in which the criterion has been successfully used.

4.2.2 The criteria in Paragraph 4.3 were developed through laboratory experiments or were determined empirically by evaluating data obtained from successfully operated cathodic protection systems. It is not intended that personnel responsible for corrosion control be limited to operating under these criteria if it can be demonstrated by other means that the control of corrosion has been achieved.

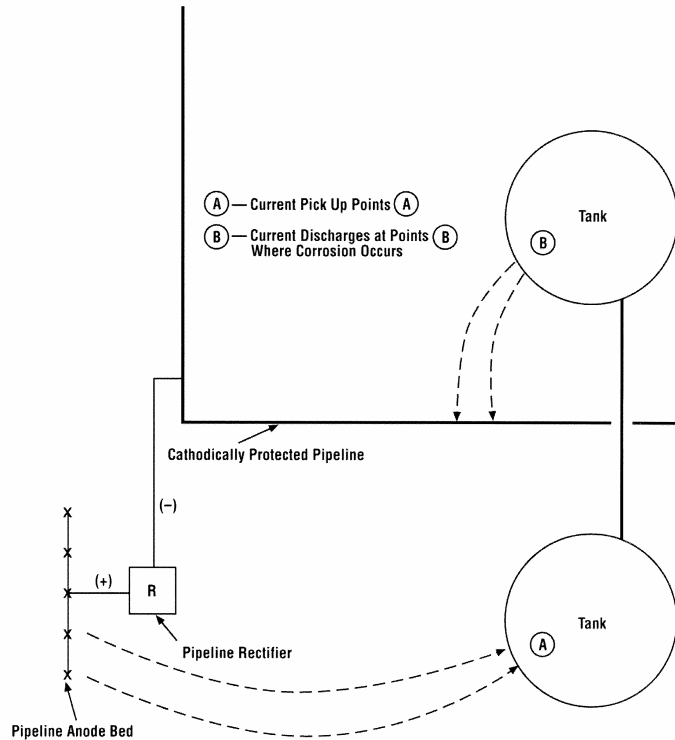

Figure 3: Stray Current Corrosion

4.2.3 Potential measurements on storage tanks shall be made with the reference electrode located as close as possible to the tank bottom. On most tanks, measurements should be taken at the perimeter, near the center of the tank bottom, and at various points in between. Consideration must be given to voltage drops other than those across the structure-to-electrolyte boundary, the presence of dissimilar metals, and the influence of other structures. These factors may interfere with valid interpretation of potential measurements. Also, measurements made with a reference electrode located on asphalt pavement or a concrete slab or outside the concrete wall may be in error.

4.3 Criteria for Corrosion Control of Carbon Steel Tank Bottoms

4.3.1 Corrosion control can be achieved at various levels of cathodic polarization depending on environmental conditions. However, in the absence of specific data that demonstrate that cathodic protection has been achieved, one or more of the following must apply to the system:

4.3.1.1 A negative (cathodic) potential of at least 850 mV with the cathodic protection current applied. This potential shall be measured with

respect to a saturated copper/copper sulfate reference electrode (CSE) contacting the electrolyte. Consideration must be given to voltage drops other than those across the structure-to-electrolyte boundary for valid interpretation of this voltage measurement.

4.3.1.1.1 Consideration is understood to mean the application of sound engineering practice in determining the significance of voltage drops by methods such as:

- (a) Measuring or calculating the voltage drop(s),
- (b) Reviewing the historical performance of the cathodic protection system,
- (c) Evaluating the physical and electrical characteristics of the tank bottom and its environment, and
- (d) Determining whether or not there is physical evidence of corrosion.

4.3.1.2 A negative polarized potential of at least 850 mV relative to a CSE.

4.3.1.3 A minimum of 100 mV of cathodic polarization between the carbon steel surface of the tank bottom and a stable reference electrode

contacting the electrolyte. The formation or decay of polarization may be measured to satisfy this criterion.

4.4 Reference Electrodes

4.4.1 Other standard reference electrodes may be substituted for the CSE. Two commonly used reference electrodes are listed below. The voltages given are equivalent (at 25°C [77°F]) to a negative 850 mV potential referred to a CSE:

- (a) Saturated silver/silver chloride reference electrode: a negative 780 mV potential
- (b) High-purity zinc (99.99%): a positive 250-mV potential (see Paragraph 7.3.4)

4.4.2 Stationary (permanently installed) reference electrodes may assist in measuring potentials under the tank. Stationary electrodes may be encapsulated in an appropriate backfill material.

4.5 Special Considerations

4.5.1 Special cases, such as stray currents and stray electrical gradients, that require the use of criteria different from those listed above may exist.

4.5.2 Coupons and electrical resistance probes may be useful in evaluating the effectiveness of the cathodic protection system.

4.5.3 Conditions in which cathodic protection is ineffective or only partially effective sometimes exist. Such conditions may include the following:

- (a) Elevated temperatures
- (b) Disbonded coatings
- (c) Shielding
- (d) Bacterial attack
- (e) Unusual contaminants in the electrolyte
- (f) Areas of the tank bottom that do not come into contact with the electrolyte
- (g) Dry tank cushion

4.5.4 Rocks, clay deposits, or clumps under tank bottom plates can promote the formation of localized corrosion activity, which is difficult to monitor or evaluate.

Section 5: General Considerations for Cathodic Protection Design

5.1 This section recommends procedures and considerations that apply to the design of cathodic protection systems for on-grade, single- and double-bottom carbon steel storage tanks.

5.2 Cathodic Protection Objectives and System Characteristics

5.2.1 The major objectives for the design of a cathodic protection system are:

- (a) To protect the tank bottom from soil-side corrosion
- (b) To provide sufficient and uniformly distributed current
- (c) To provide a design life commensurate with the design life of the tank bottom or to provide for periodic anode replacement
- (d) To minimize interference currents
- (e) To provide adequate allowance for anticipated changes in current requirements for protection
- (f) To locate and install system components where the possibility of damage is minimal
- (g) To provide adequate monitoring facilities to permit a determination of the system's performance (see Paragraph 11.2)

5.2.2 General characteristics of impressed current and galvanic current cathodic protection systems are listed

in Table 1. Impressed current systems are usually used if the service temperature is elevated, or if other factors require higher current densities. Impressed current systems are also used if higher driving potentials are needed due to the presence of high-resistance electrolytes, or if the economic benefit of such a system is considered significant to the project.

5.2.3 An impressed current cathodic protection system is powered by an external source of direct current. The positive terminal of the direct current source is connected through insulated conductors to the anode system. The negative terminal of the direct current source is electrically connected to the tank bottom to be protected. Anode systems for on-grade storage tanks can include shallow groundbeds around or under the tank and/or deep anode groundbeds.

5.2.3.1 Satisfactory anode materials include mixed-metal oxides, polymer carbon, graphite, high-silicon chromium-bearing cast iron, platinized niobium (columbium), platinized titanium, scrap metal, and belowgrade metallic structures that have been removed from service and cleaned of contaminants. Anode selection should be based on soil chemistry, contaminants, and the compatibility of the anode with the environment.

5.2.4 Galvanic current cathodic protection systems operate on the principle of dissimilar-metals corrosion. The anode in a galvanic current system must be more electrochemically active than the structure to be protected. Cathodic protection using a galvanic system

is afforded by providing an electrical connection between the anode system and the storage tank bottom. Typical galvanic current anode materials for storage tank bottom applications include magnesium and zinc.

**TABLE 1
Cathodic Protection System Characteristics**

Galvanic Current	Impressed Current
No external power required	External power required
Fixed, limited driving voltage	Driving voltage can be varied
Limited current	Current can be varied
Satisfies small current requirements	Satisfies high current requirements
Used in lower-resistivity environments	Used in higher-resistivity environments
Usually no stray current interference	Must consider interference with other structures

5.3 In the design of a cathodic protection system, the following shall be considered:

- (a) Recognition of hazardous conditions prevailing at the site and the selection and specification of materials and installation practices that ensure safe installation and operation
- (b) Compliance with all applicable governmental codes and owner requirements
- (c) Selection and specification of materials and installation practices that ensure dependable and economic operation of the system throughout its intended operating life
- (d) Design of proposed installation to minimize stray currents
- (e) Avoiding excessive levels of cathodic protection, which may cause coating disbondment and possible damage to high-strength and special alloy steels
- (f) If amphoteric metals are involved (i.e., lead, tin, aluminum), avoiding high or low pH conditions that could cause corrosion
- (g) Presence of secondary containment systems

5.4 Current Requirement

5.4.1 The preferred method of determining the current requirements for achieving a given level of protection on an existing tank bottom is to test the tank bottom using a temporary cathodic protection system. Alternately, a current density can be used for design purposes based on a current density successfully used at the same facility or at a facility with similar characteristics.

5.4.2 For design purposes, current requirements on new or proposed tank bottoms may be established by calculating surface areas and applying a protective current density based on the size of the tank, the electrochemical characteristics of the environment, the service temperature, and the parameters of the groundbed. Design current densities of 10 to 20 mA/m² (1 to 2 mA/ft²) of bare tank bottom surface are generally sufficient. Systems exposed to chemistry involving chlorides, sulfides, or bacteria or to elevated

service temperatures require more current. The history of other tanks in the same environment should be considered when choosing a design current density.

5.4.3 Care must be exercised to ensure that anode type and placement result in uniform distribution of protective current to the tank bottom surfaces.

5.4.4 Liquid levels within tanks must be sufficient to ensure that the entire tank bottom is in intimate contact with an electrolyte while establishing current requirements and testing applied protection levels. Adequate liquid levels are important to maintaining polarization.

5.4.4.1 As the liquid level increases (and more of the tank bottom contacts the electrolyte), the protective current requirement increases and the potential measured may decrease due to the increased surface area of steel contacting the electrolyte.

5.5 Tank System Configuration

5.5.1 Design, materials, and construction procedures that do not create shielding conditions should be used.

5.5.2 Nonwelded mechanical joints might not be electrically continuous. Electrical continuity can be ensured by bonding existing joints.

5.5.3 If electrical isolation is required, care must be taken to assure that the isolation is not shorted, bypassed, etc.

5.6 Special consideration should be given to the presence of sulfides, chlorides, bacteria, coatings, elevated temperatures, shielding, pH conditions, treated tank padding material, soil/groundwater contamination, dissimilar metals, and pad/concrete/metal interface at the ringwall, as well as any heating or refrigeration coils under tank bottoms. Clean, fine sand is the preferred tank pad material.

5.7 On-grade tanks that are set on solid concrete or asphalt pad foundations generally require specialized measures for corrosion protection, because cathodic protection may be ineffective. In this circumstance, the external surface of the tank bottom should be coated. In all cases, steps should be taken to ensure that water does not migrate between the tank bottom and the pad.

5.7.1 Providing electrical isolation between the reinforcing steel and the tank bottom should be considered if a concrete ringwall or pad is used.

5.8 Design Drawings and Specifications

5.8.1 Specifications should be prepared for all materials and installation procedures that are used during construction of the cathodic protection system.

5.8.2 Suitable drawings should be prepared to show the overall layout of the tank bottoms to be protected and the cathodic protection system and associated appurtenances.

Section 6: Design Considerations for Impressed Current Cathodic Protection

6.1 This section recommends procedures and considerations that specifically apply to the design of impressed current cathodic protection systems for on-grade carbon steel storage tank bottoms.

6.2 Impressed Current Anode Systems

6.2.1 Impressed current anodes shall be connected with an insulated cable, either singularly or in groups, to the positive terminal of a direct current source such as a rectifier or DC generator. The tank bottom shall be electrically connected to the negative terminal. Cable insulation should be selected based on the anticipated environmental conditions and should be resistant to oil and water.

6.2.2 Anode groundbed configurations may be vertical, angled, deep, or horizontal, as illustrated in Figures 4 through 7. Anodes may be installed in a distributed fashion under tank bottoms. The selection of anode configuration is dependent on environmental factors, current requirements, the size and type of tank bottom to be protected, whether the tank is of new or existing construction, and whether it is a single- or double-bottom tank.

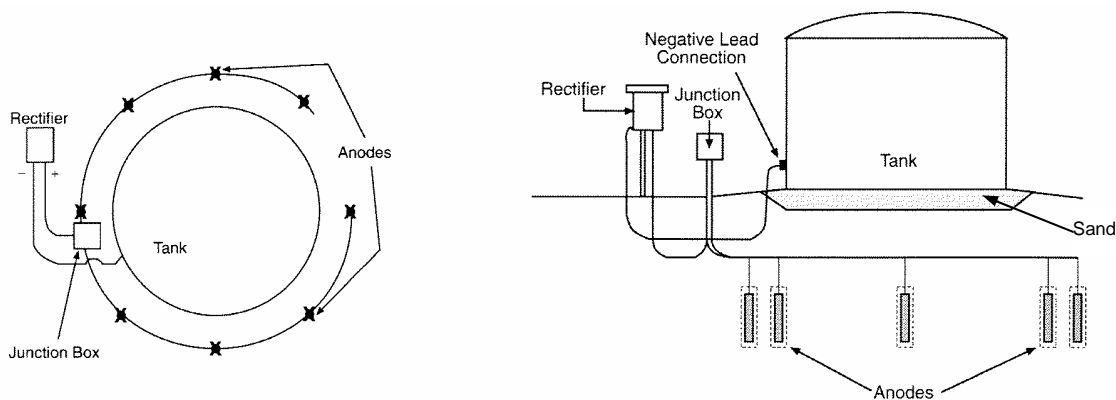

Figure 4: Vertically Drilled Anode CP System

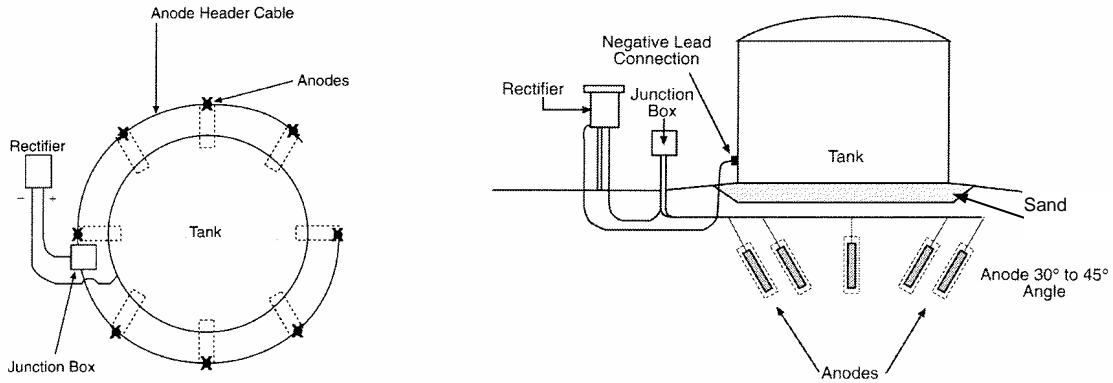

Figure 5: Angled Anode Cathodic Protection System

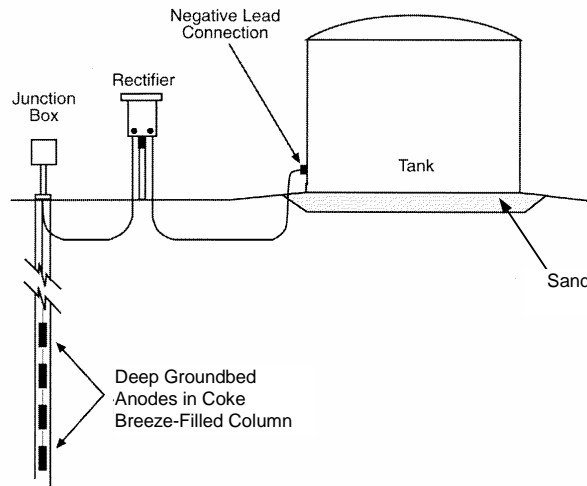

Figure 6: Deep Anode Groundbed

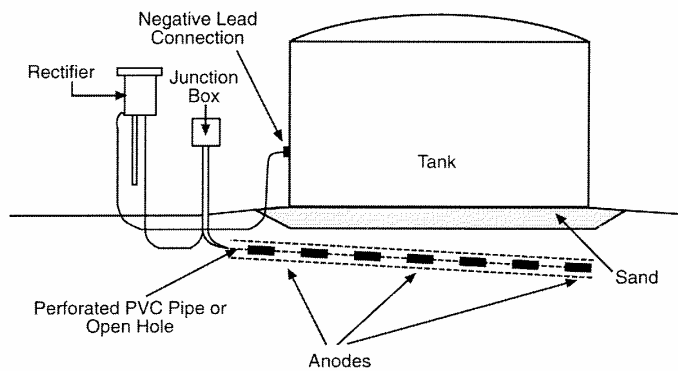

Figure 7: Horizontally Installed Anode Groundbed

6.2.3 Deep anode systems should be designed and installed in accordance with NACE Standard RP0572.⁴

6.2.4 Anode materials have varying rates of deterioration when discharging current. Therefore, for

a given output, the anode life depends on the environment, anode material, anode weight, and the number of anodes in the cathodic protection system. Established anode performance data should be used to calculate the probable life of the system.

NOTE: Platinized niobium (columbium) and polymeric anodes should not be used in hydrocarbon-contaminated environments.

6.2.5 The useful life of impressed current anodes can be lengthened by the use of special backfill around the anodes. The most commonly used backfill materials are metallurgical coal coke and calcined petroleum coke. Because coke is noble compared to carbon steel, coke should not be allowed to come into contact with the tank bottom.

6.2.6 In the design of an extensive, distributed-anode impressed current system, the voltage and current attenuation along the anode and the anode-connecting (header) cable should be considered. In such cases, the design objective should be to optimize anode system length, anode size and spacing, and cable size in order to achieve effective corrosion control over the entire surface of each tank bottom.

6.2.7 Suitable provisions for venting the anodes should be made in situations in which it is anticipated that entrapment of gas generated by anodic reactions could impair the ability of the impressed current grounded to deliver the required current. Venting systems must be designed to prevent contaminants from getting into the venting system.

6.3 Safety

6.3.1 All impressed current systems must be designed with safety in mind. Care must be taken to ensure that all cables are protected from physical damage and the possibility of arcing.

6.3.2 Rectifiers and junction boxes must meet regulatory requirements for the specific location and environment in which they are installed. Such locations shall be determined by reviewing regulatory agency and prevailing industrial codes.

6.3.2.1 Consideration should be given to locating isolating devices, junction boxes, and rectifiers outside hazardous areas in case sparks or arcs occur during testing.

6.3.3 In order to prevent arcing, care must be exercised when working on piping attached to tanks with cathodic protection applied. When cathodic protection systems are turned off, sufficient time must be allowed for depolarization before opening connections. Bonding cables must be used when parting piping joints.

Section 7: Design Considerations for Galvanic Anode Cathodic Protection

7.1 This section describes the factors that should be considered in the design of external corrosion protection of on-grade carbon steel storage tank bottoms without secondary containment that are protected by galvanic anode cathodic protection.

7.2 Galvanic protection systems may be applied to a tank bottom if the carbon steel surface area exposed to the electrolyte can be minimized through the application of a dielectric coating, the surface area is small due to the tank size or configuration, or no power source or impressed current source is available.

7.2.1 Galvanic anodes should be connected to the tank bottom through a test station so that anode performance and voltage drops can be monitored.

7.2.2 In applications for which the tank bottom is either uncoated or large due to the tank size or configuration, the use of impressed current cathodic protection should be considered to minimize the cost of the protection system. Section 6 provides more information regarding the design considerations for impressed current cathodic protection systems.

7.3 Galvanic Anode Selection

7.3.1 The three most common types of galvanic anodes effective in soil environments are standard magnesium, high-potential magnesium, and high-purity zinc.

7.3.2 The selection and use of these anodes should be based on the current requirements of the tank bottom, the soil conditions, the temperature of the tank bottom, and the cost of the materials.

7.3.3 The current available from each type of anode depends greatly on the soil conditions, the anode shape (whether bar, block, or ribbon), and the driving potential of the anode.

7.3.4 If high-purity zinc anodes are employed, care should be exercised to ensure that the anodes meet the requirements of ASTM B 4185 Type II anode material. The purity of the zinc can greatly affect the performance of the material as a galvanic anode for soil applications.

7.3.5 Zinc anodes should not be used if the temperature of the anode environment is above 49°C (120°F). Higher temperatures can cause passivation of the anode. The presence of salts such as carbonates,

RP0193-2001

bicarbonates, or nitrates in the electrolyte may also affect the performance of zinc as an anode material.

7.3.6 Galvanic anode performance may be enhanced in most soils by using special backfill material. Mixtures of gypsum, bentonite, and sodium sulfate are the most common.

7.3.7 Galvanic anodes (except for rebar-type anodes) should be supplied with adequate lead wire attached by the anode supplier.

7.3.7.1 Lead wire should be at least 2 mm in diameter (#12 AWG [American Wire Gauge.]) Cable insulation should be selected based on the anticipated environmental conditions and should typically be resistant to oil and water.

Section 8: Design Considerations — Cathodic Protection for Tanks with Replacement Bottoms or Release-Prevention Barriers

8.1 Introduction

8.1.1 Release-prevention barriers and replacement tank bottoms can be used together or separately.

8.1.2 Release-prevention barriers and/or secondary carbon steel tank bottoms may shield the carbon steel surface of the primary tank bottom from the flow of cathodic protection current, resulting in a lack of adequate cathodic protection.

8.1.3 Any impact (i.e., corrosiveness) that the fill material beneath or between the tank bottoms could have on the cathodic protection system should be considered.

8.2 Release-Prevention Barriers

8.2.1 Impervious membranes or liners constructed of a nonconductive material used as a release-prevention barrier can prevent the flow of cathodic protection current from anodes located outside the barrier envelope. Anodes must be placed between the barrier and the carbon steel tank bottom so that current flows to the surfaces requiring protection.

If release-prevention barriers made of conductive material are used with a cathodic protection system with anodes outside the space contained by the barrier, the barrier must maintain a resistance low enough for sufficient cathodic protection current to flow to the tank bottom.

8.2.2 Stationary reference electrodes and/or portable reference electrode insertion tubes must be located between the carbon steel tank bottom and the barrier or between the bottoms to obtain accurate structure-to-electrolyte data.

8.3 Replacement Tank Bottoms

8.3.1 If a replacement tank bottom is installed in an existing tank over an original bottom so that there is an electrolyte between the two tank bottoms, galvanic corrosion activity can develop on the new bottom, resulting in premature failure.

8.3.2 Cathodic protection should be considered for the primary (new) bottom. The anodes and reference electrodes or nonconductive reference electrode insertion tubes must be placed in the electrolyte between the two bottoms. Figure 8 illustrates a typical double-bottom cathodic protection layout.

8.3.3 The installation of a nonconductive, impervious membrane or liner above the original bottom reduces galvanic corrosion activity on the replacement bottom, reducing the current required for cathodic protection.

8.3.4 If the original tank bottom is removed and replaced with a new bottom, the cathodic protection design should be that utilized for a standard, single-bottom tank.

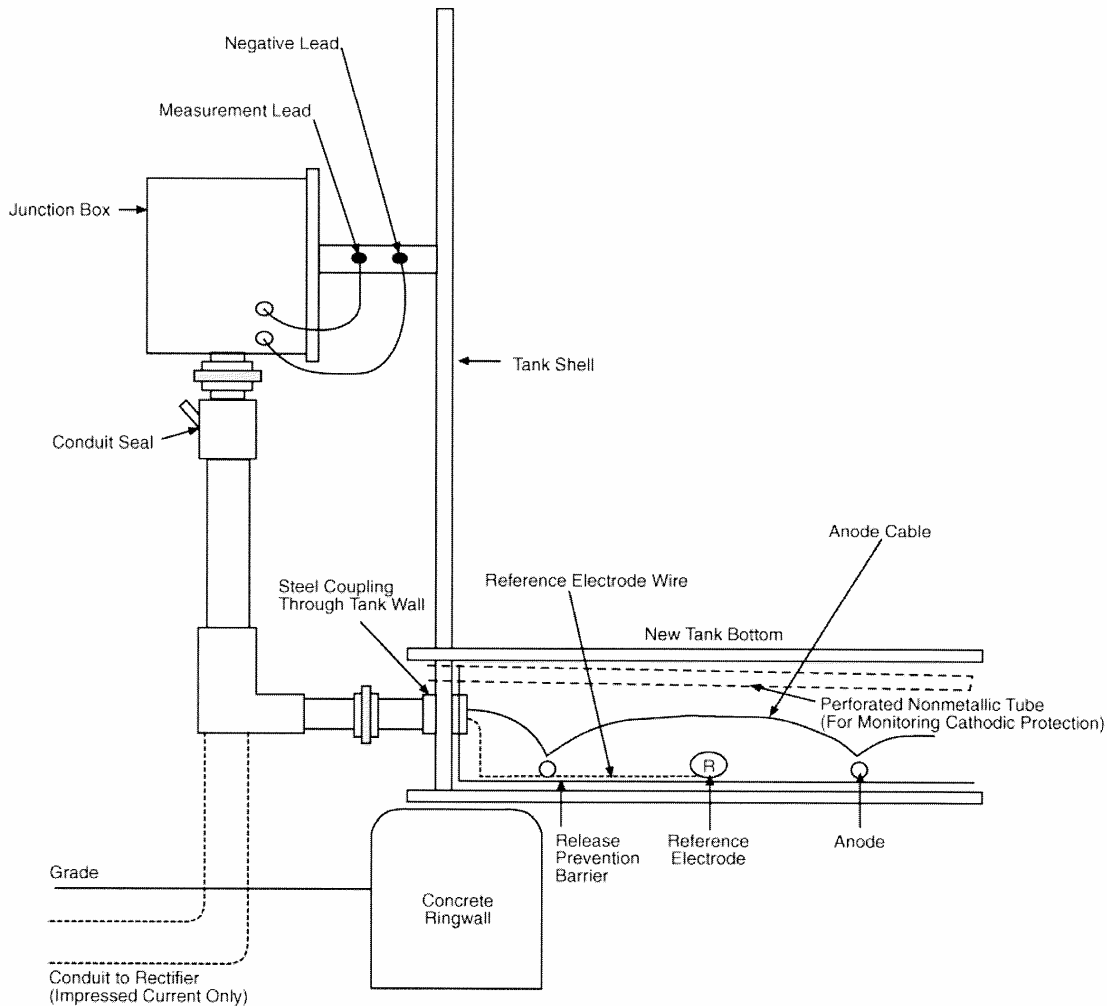

Figure 8: Typical Double-Bottom Cathodic Protection Layout (Impressed or Sacrificial)

8.4 Cathodic Protection Anodes

8.4.1 Either impressed current or galvanic anode cathodic protection may be used.

8.4.1.1 Galvanic anodes may be magnesium or zinc. Figure 9 illustrates a typical double-bottom galvanic anode design.

8.4.1.2 Anode materials that may be used for impressed current systems include mixed-metal oxides, polymer carbon, graphite, high-silicon chromium-bearing cast iron, platinized niobium (columbium), platinized titanium, scrap metal, and below-grade metallic structures that have been removed from service. Figure 10 illustrates a typical new tank or double-bottom impressed current anode design.

8.4.1.3 Due to the depolarizing effect of oxidation by-products (typically chlorine, oxygen,

or carbon dioxide) migrating from the anode to the steel cathode, the current density for protection with an impressed current system may be higher than that required for a galvanic anode system.

8.4.2 Adequate space must be provided between the two tank bottoms to allow for installation of a cathodic protection system with uniform current distribution from the anodes. Due to limited space between bottoms, close anode spacing may be required to improve current distribution.

Impressed current anodes must not contact the carbon steel surfaces of the tank.

8.4.4 Anodes must be installed in a conductive electrolyte. The electrolyte must be sufficiently compacted as to prevent settlement of the replacement tank bottom.

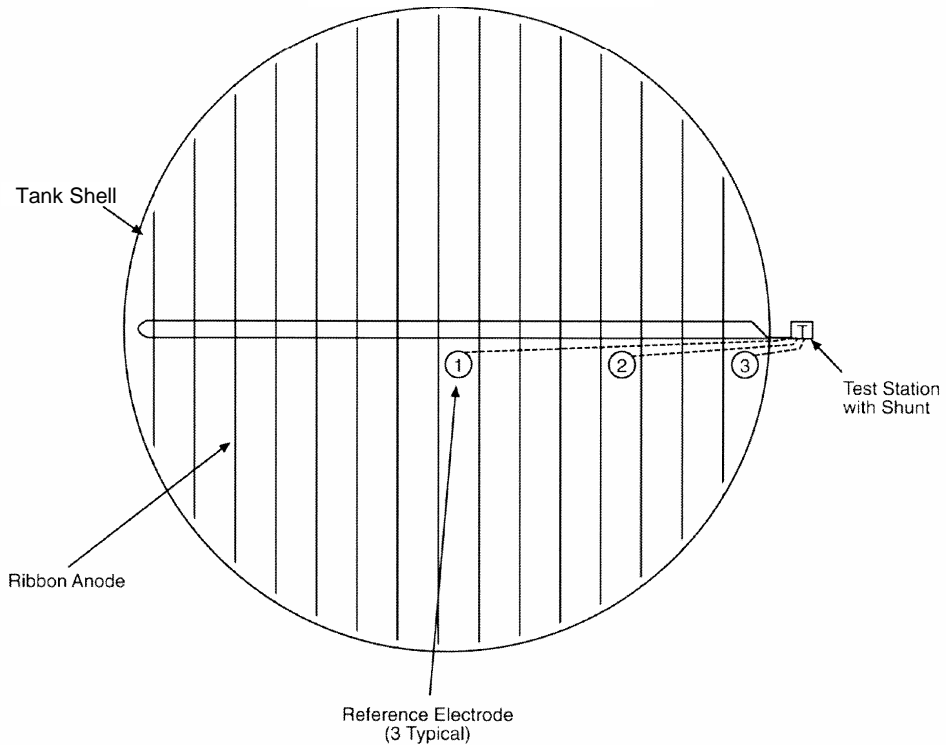

Figure 9: Typical Double-Bottom Galvanic Anode Design

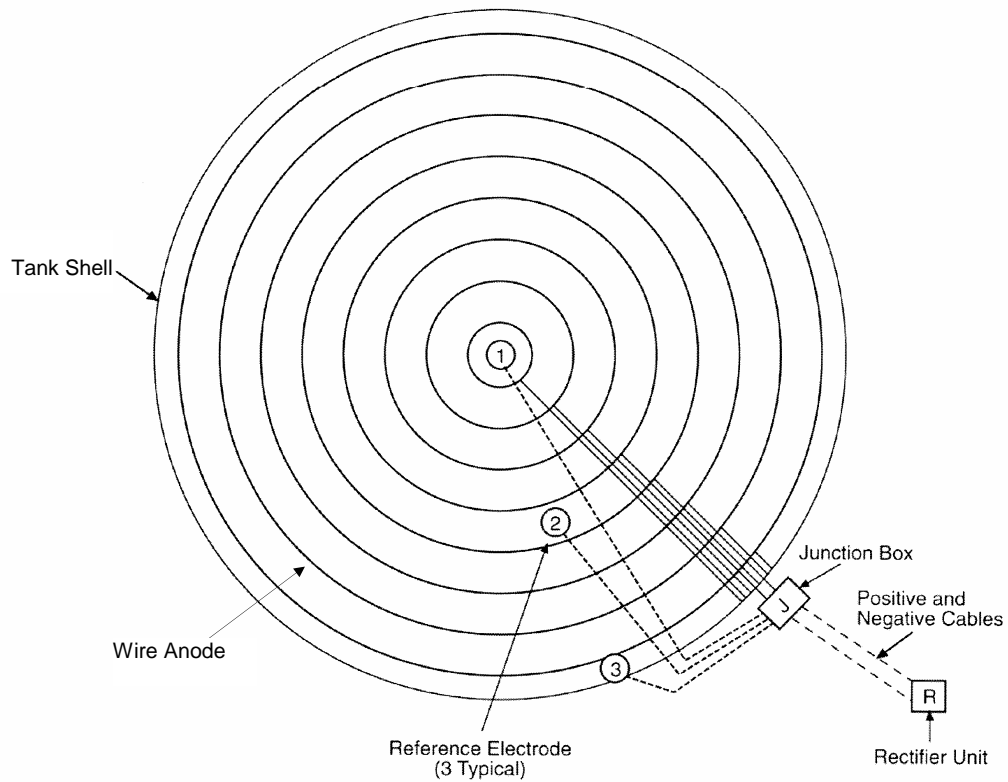

Figure 10: Typical New Tank or Double-Bottom Impressed Current Anode Design

Section 9: Installation Considerations

9.1 This section recommends elements to consider during the installation of cathodic protection systems for on-grade carbon steel storage tank bottoms.

9.2 Preparation

9.2.1 Materials should be inspected prior to installation in order to ensure that specifications have been met.

9.2.2 Installation practices shall conform to all applicable regulatory agencies codes and requirements.

9.3 Anode Installation

9.3.1 Anodes should be installed as designed. Care must be taken to ensure that the anodes do not come into electrical contact with any piping or tankage during installation.

9.3.2 Slack should be allowed in the anode lead wires to avoid possible damage due to settlement of the tank and surrounding soils. Anodes, lead wires, and connections should be handled with care to prevent damage or breakage.

9.3.3 The anode lead wires should be extended to the side of the tank away from the construction to minimize possible damage. After the tank foundation has been prepared and the tank set in place, the wires should be terminated in a test station or junction box, which may include shunts for measuring anode current outputs.

9.4 Reference Electrodes

9.4.1 Stationary reference electrodes or nonconductive, perforated tubes for temporary installation of a portable reference electrode should be installed under all tanks regardless of the groundbed type and location.

9.4.1.1 Stationary reference electrodes may be prepackaged in a backfill and placed in the soil

under the tank bottom or positioned inside the perforated reference electrode access piping. Reference electrodes placed inside access piping should be surrounded with a backfill material designed to provide contact between the electrode and the electrolyte outside the pipe. If practical, provisions should be made for future verification of all stationary reference electrode potentials with portable reference electrodes.

9.4.1.2 Reference electrode access piping must have some means of contact with the electrolyte and should have at least one end accessible from outside the tank shell. This contact can be through the use of holes, slits, or not capping the end of the piping beneath the tank. Perforations and slots should be designed to minimize entry of tank pad material. Portable reference electrodes shall be inserted through the inside diameter of the access pipe with a nonmetallic material such as small-diameter polyvinyl chloride (PVC) pipe. Inserting a reference electrode with metallic tape, bare wires, etc., may adversely affect potential readings. If necessary, water should be injected inside the access pipe to establish continuity between the electrode and the electrolyte. Deionized water should be used for double-bottom tanks or tanks with secondary containment.

9.4.2 For existing tanks, reference electrode access piping should be installed under the tank with horizontal drilling equipment capable of providing guidance and directional control to prevent tank bottom damage and to ensure accurate placement of the piping. Consideration must be given to the structural aspects of the tank padding and foundation to ensure that support capabilities are not adversely affected. Figure 11 illustrates the placement of perforated pipe installed for a reference electrode.

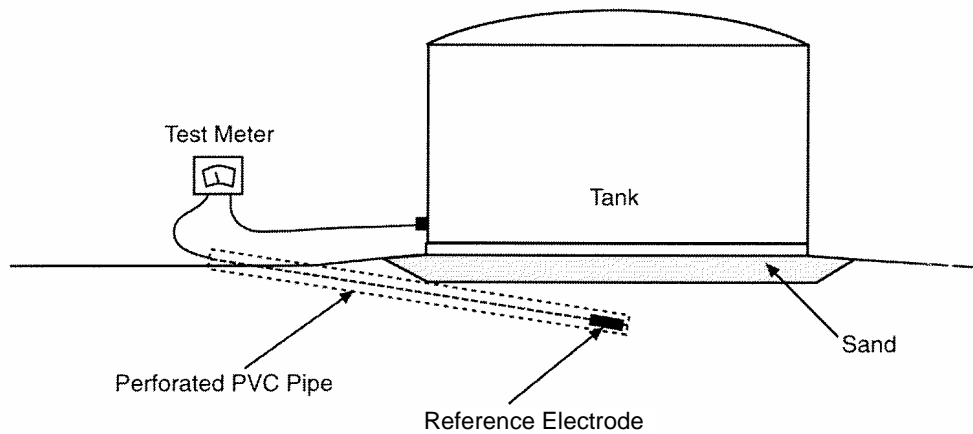

Figure 11: Perforated Pipe Installed for Reference Electrode

NOTE: Special consideration must be given during the design and installation of access pipes to assure that any tank-containment system is not breached.

CAUTION: Extreme caution must be exercised when boring or water jetting under tanks.

9.4.2.1 A constant distance should be maintained from the tank bottom to the reference electrode. Increasing space between tank bottom and reference electrode increases the voltage drop.

9.5 Test Stations and Junction Boxes

9.5.1 Test stations or junction boxes for potential and current measurements should be provided at sufficient locations to facilitate cathodic protection testing.

9.5.2 The test station or junction box should be mounted on or near the side of the tank in an area that is protected from vehicular traffic.

9.5.3 The test station or junction box should allow for disconnection of the anodes to facilitate current measurements and potential measurements for voltage drop as required to evaluate the protection level. If desired, test leads from buried reference electrodes can be terminated in the same test station as tank bottom test wires.

9.5.4 Junction boxes can be used to connect continuity bonds or protective devices.

9.5.5 The test station or junction box in a galvanic system may be equipped with calibrated resistors (shunts) in connections between the anodes and the tank to measure the anode current output and thus the estimated anode life. Shunts are typically rated between 0.001 and 0.1 ohm.

9.5.6 The test station or junction box should be clearly marked and accessible for future monitoring of the tank bottom and, if possible, should be attached to the tank.

9.5.7 All lead wires to the test station or junction box should be protected from damage by a minimum 46-cm (18-in.) burial and/or placement within a conduit. Warning tape may be installed over direct-buried cables to prevent the possibility of damage during future excavation.

9.6 Safety Considerations

9.6.1 All personnel to be involved in the installation of the cathodic protection system should participate in a thorough safety-training program.

9.6.2 All underground facilities, including buried electric cables and pipelines in the affected areas, should be located and marked prior to digging.

9.6.3 All utility companies and other companies with facilities crossing the work areas should be notified and their affected structures located and marked prior to digging.

9.6.4 All areas with low overhead wires, pipelines, and other structures should be located and noted prior to any construction.

9.6.5 Operations and maintenance personnel should be notified of pending construction to coordinate necessary shutdowns or emergency considerations.

Section 10: Energizing and Testing

10.1 This section discusses factors that should be considered when energizing and testing a cathodic protection system for on-grade carbon steel storage tank bottoms. If the tank has a secondary containment system, suitable access ports through the ringwall must be provided for testing.

10.2 Design Parameters

10.2.1 Knowledge of the performance criteria considered during the design of a cathodic protection system as well as the operational limits of cathodic protection devices and hardware should be available to the personnel setting operating levels for the cathodic protection system.

10.3 Initial Data

10.3.1 Verification of cathodic protection devices and hardware, such as the following, should be done prior to energizing:

- (a) Location of anodes
- (b) Ratings of impressed current sources
- (c) Location of reference electrodes
- (d) Location of test facilities
- (e) Location of cathodic protection system cables

10.3.2 Prior to energizing the cathodic protection system, the following data and information should be collected:

- (a) Tank bottom-to-electrolyte potentials
- (b) Pipe-to-electrolyte potentials on connected piping
- (c) Verification of dielectric isolation
- (d) Foreign structure-to-electrolyte potentials
- (e) Test coupon data
- (f) Fluid level in the tank during testing, and
- (f) Corrosion-rate probe data.

10.3.3 All initial baseline data should be documented and the records maintained for the life of the cathodic protection system or the on-grade storage tank. Any deviations from the design or as-built documentation should be noted and included with the initial baseline data.

10.3.4 When measuring the structure-to-electrolyte potential, the portable reference electrodes should be placed at sufficient intervals around the perimeter and under the tank to ensure the potentials measured are representative of the entire tank bottom. The potential measured at the perimeter of a large-diameter tank does not represent the potential at the center of the tank.

10.4 Current Adjustment

10.4.1 The desired operating level of a cathodic protection system must often be determined by a series of trial tests at various operating levels. The specific operating level depends on the criterion for cathodic protection used for the on-grade storage tank(s). Section 4 defines the various criteria for achieving cathodic protection of on-grade carbon steel storage tank bottoms. Time required to achieve polarization on a bare tank bottom can be different from tank to tank.

10.4.2 When the operating levels of cathodic protection systems are adjusted, consideration must be given to the effect of stray current on adjacent structures. Owners of these structures should be notified of the installation of a new cathodic protection system.

10.4.2.1 Among the structures that should be considered as being possibly affected by stray current are:

- (a) On-grade and buried storage tanks
- (b) Piping separated from the tank(s) by high-resistance fittings
- (c) Buried electric facilities
- (d) Buried fire-protection piping
- (e) Buried water piping
- (f) Transmission or distribution piping serving storage tank(s)
- (g) Municipal or public utility structures serving the facility in which a storage tank(s) is located
- (h) Fencing

10.4.2.2 Structures that may contain discontinuous fittings or joints, such as cast iron systems, ductile iron piping systems, or piping with mechanically connected fittings, require special attention to ensure that stray current effects are detected and mitigated.

10.4.3 The final operating level of a cathodic protection system should be established to achieve the cathodic protection criterion established by the design documents as set forth in Section 4, or by the operating policies of the facility owner.

10.5 Documentation

10.5.1 Documentation of all operating parameters should be completed after the system is energized. Those parameters should include:

- (a) Initial baseline data
- (b) As-built drawings

RP0193-2001

- (c) Operating currents
- (d) Locations of test facilities
- (e) Key monitoring locations
- (f) Equipment manuals
- (g) Tank fluid level

10.5.2 All collected data should be recorded and documented for future reference.

10.6 Error Sources: Consideration must be given to sources of error when potential readings are made on aboveground storage tank (AST) bottoms. Some of these error sources include:

10.6.1 Measurement Circuit IR Drop: The soil or fill under a tank bottom can be dry and have a high electrolyte resistance. Under these conditions, an IR drop error occurs in the measuring circuit if a low-input impedance meter is used. This error can be

minimized using a meter with an input impedance greater than 10^6 ohms.

10.6.2 Tank Bottom Flexing: When product level is low, the tank bottom can shift upward, affecting the measurement circuit and changing the area of the tank bottom being monitored. This may result in misleading readings. This error can be minimized by ensuring that there is sufficient product level in the tank during measurements.

10.6.3 Measurements Made from Grade Wall (single-bottom tanks): Potential measurements made from grade are strongly influenced by the potentials at the perimeter of the tank bottom or outside the ringwall (if present). To measure the potentials correctly in the center of the tank bottom, it is necessary to use either a stationary reference electrode, or to have an access tube located under the tank bottom.

Section 11: Operation and Maintenance of Cathodic Protection Systems

11.1 This section recommends procedures and practices for maintaining the effective and efficient operation of cathodic protection systems for on-grade carbon steel storage tank bottoms.

11.2 Monitoring Cathodic Protection Systems

11.2.1 The protection systems shall be monitored to ensure adequate cathodic protection of the tank bottoms in accordance with the criteria set forth in Section 4.

11.2.2 Annual surveys should be conducted to verify that the cathodic protection system is meeting the protection criteria. Making more frequent surveys of the system may be desirable in critically corrosive environments or where highly variable conditions are present. The accuracy of stationary reference electrodes should be evaluated during these surveys. The effectiveness of isolating fittings and continuity bonds should also be evaluated during the periodic surveys.

11.2.3 All sources of impressed current should be checked at bimonthly intervals to ensure effective operation of the system. Current and voltage outputs consistent with previous readings or a satisfactory polarized potential measured at the protected tank bottom surface may each be considered evidence of proper functioning.

11.2.4 Potential testing should consist of a minimum of four equally spaced tests on the external circumference and at least one test at the center of the bottom on tanks of 18-m (60-ft) diameter or less. On tanks greater than 18 m (60 ft) in diameter, eight

equally spaced tests on the external circumference and at least one test at the center of the tank bottom should be the minimum testing requirement.

11.2.4.1 Experience has indicated that on large tanks, potential measurements obtained at the perimeter of the tank may not reflect the actual conditions of the entire tank bottom.

11.2.4.2 Potential measurements may be affected by liquid-level changes inside the tank.

11.2.4.3 The cathodic protection system should be monitored for the existence of any stray current interference from adjacent structures or protection systems.

11.2.5 All cathodic protection systems should be inspected as part of a predictive/preventive maintenance program to minimize in-service failure. Inspections should include a check for electrical shorts, ground connections, meter accuracy, rectifier efficiency, and circuit resistance. Scheduled maintenance should include removing debris at the rectifier openings required for cooling and checking to ensure that all connections are secure and unaffected by corrosion. Maintenance should include inspection of junction boxes, test stations, and other equipment.

11.3 Test equipment used for obtaining cathodic protection data should be checked periodically for accuracy and maintained in good operating condition.

11.4 Corrective action shall be taken if surveys and inspections indicate that the cathodic protection system is

no longer providing adequate protection. These actions include the following:

- (a) Repair, replacement, or adjustment of components of the cathodic protection system
- (b) Addition of supplementary cathodic protection when necessary

(c) Repair, replacement, or adjustment of continuity bonds and continuity devices.

11.5 Care should be exercised to ensure that remedial measures intended to restore or enhance protection do not compromise the integrity of liners or membranes.

Section 12: Recordkeeping

12.1 This section recommends pertinent information that should be recorded and filed for future information and reference.

12.2 Tank information should include, but not be limited to, the information outlined in Paragraph 3.2.

12.3 Design and installation records for cathodic protection systems should be kept, including the following information:

- (a) Design calculations and considerations
- (b) Power source capacity, circuit breakers, panels, etc.
- (c) Number of anodes
- (d) Anode material and expected life
- (e) Anode installation details
- (f) Type, quantity, and location of stationary reference electrodes

- (g) Soil resistivity
- (h) Date of energizing and initial current and voltage settings
- (i) Cost of system
- (j) Fluid level in the tank during survey
- (k) As-built drawings of the installation

12.4 Operation and maintenance records for cathodic protection systems should be kept, including the following information:

- (a) Tabulations of bimonthly readings of impressed current power source
- (b) Reports of periodic or annual inspections
- (c) All adjustments, repairs, and additions
- (d) Costs of maintenance
- (e) Test equipment calibration records

References

1. ASTM G 57 (latest revision), "Standard Test Method for Field Measurement of Soil Resistivity Using the Wenner Four-Electrode Method" (West Conshohocken, PA: ASTM).
2. F.W. Hewes, "Prediction of Shallow and Deep Groundbed Resistance Using Electromagnetic Conductivity Measurement Techniques," CORROSION/87, paper no. 130 (Houston, TX: NACE International, 1987).
3. H.E. Barnes, "Electrical Survey Detects Underground Rock," Pipeline Industry, April 1959.
4. NACE Standard RP0572 (latest revision), "Design, Installation, Operation, and Maintenance of Impressed Current Deep Groundbeds" (Houston, TX: NACE).
5. ASTM Standard B 418 (latest revision), "Standard Specification for Cast and Wrought Galvanic Zinc Anodes" (West Conshohocken, PA: ASTM).

Bibliography

- Ewing, S.P. "Potential Measurements for Determination of Cathodic Protection Requirements." *Corrosion* 7, 12 (1951): p. 410.
- Kuhn, R.J. "Criteria for Steel and Cast Iron." *Cathodic Protection of Underground Pipelines against Soil Corrosion — Proceedings of the American Petroleum Institute* 4, 14 (1953): p. 153.
- McDorman, O.N. "Potential and Current Requirements for the Cathodic Protection of Steel in Soils." *Corrosion* 8, 11 (1952): p. 391.
- Morgan, J.H. *Cathodic Protection*, 2nd edition. Houston, TX: NACE, 1987.

RP0193-2001

NACE Publication 56-12. "Contributions of J.M. Pearson to Mitigation of Underground Corrosion." Houston, TX: NACE, 1956. (Out of print).

NACE Standard RP0169 (latest revision). "Control of External Corrosion on Underground or Submerged Metallic Piping Systems." Houston, TX: NACE.

Pearson, J.M. "Electrical Instruments and Measurements in Cathodic Protection." *Corrosion* 3, 11 (1947): p. 549.

"Underground Corrosion." National Institute for Standards and Technology.⁽³⁾ Circular 579. April 1957, pp. 180-186 (Available from the U.S. Dept. of Commerce Clearinghouse).⁽⁴⁾

⁽³⁾ National Institute for Standards and Technology (NIST), Gaithersburg, MD 20899.

⁽⁴⁾ U.S. Department of Commerce Clearinghouse, Springfield, VA 22151.