

Standard Recommended Practice

Electrical Isolation of Cathodically Protected Pipelines

This NACE International standard represents a consensus of those individual members who have reviewed this document, its scope, and provisions. Its acceptance does not in any respect preclude anyone, whether he has adopted the standard or not, from manufacturing, marketing, purchasing, or using products, processes, or procedures not in conformance with this standard. Nothing contained in this NACE International standard is to be construed as granting any right, by implication or otherwise, to manufacture, sell, or use in connection with any method, apparatus, or product covered by Letters Patent, or as indemnifying or protecting anyone against liability for infringement of Letters Patent. This standard represents minimum requirements and should in no way be interpreted as a restriction on the use of better procedures or materials. Neither is this standard intended to apply in all cases relating to the subject. Unpredictable circumstances may negate the usefulness of this standard in specific instances. NACE International assumes no responsibility for the interpretation or use of this standard by other parties and accepts responsibility for only those official NACE International interpretations issued by NACE International in accordance with its governing procedures and policies which preclude the issuance of interpretations by individual volunteers.

Users of this NACE International standard are responsible for reviewing appropriate health, safety, environmental, and regulatory documents and for determining their applicability in relation to this standard prior to its use. This NACE International standard may not necessarily address all potential health and safety problems or environmental hazards associated with the use of materials, equipment, and/or operations detailed or referred to within this standard. Users of this NACE International standard are also responsible for establishing appropriate health, safety, and environmental protection practices, in consultation with appropriate regulatory authorities if necessary, to achieve compliance with any existing applicable regulatory requirements prior to the use of this standard.

CAUTIONARY NOTICE: NACE International standards are subject to periodic review, and may be revised or withdrawn at any time without prior notice. NACE International requires that action be taken to reaffirm, revise, or withdraw this standard no later than five years from the date of initial publication. The user is cautioned to obtain the latest edition. Purchasers of NACE International standards may receive current information on all standards and other NACE International publications by contacting the NACE International Membership Services Department, 1440 South Creek Dr., Houston, Texas 77084-4906 (telephone +1[281]228-6200).

Reaffirmed 2002-04-11
Revised 1997-June-27
Approved 1986
NACE International
1440 South Creek Drive
Houston, Texas 77084-4906
+1 281/228-6200

ISBN 1-57590-041-6
© 2002, NACE International

Foreword

This standard recommended practice is to be used in conjunction with the latest revisions of NACE Standards RP0169¹ and RP0177.² Each of these standards refers to electrical isolation or isolation joints, but details are not provided. This standard, which was prepared to supplement those standards, provides engineers, designers, and technical personnel dealing with pipelines the necessary information to isolate cathodically protected pipelines electrically.

This standard was originally prepared in 1986 and revised in 1997 by former Task Group T-10A-15 on Electrical Isolation of Cathodically Protected Pipelines, a component of Unit Committee T-10A on Cathodic Protection. The standard was reaffirmed in 2002 by Specific Technology Group (STG) 35 on Pipelines, Tanks, and Well Casings. It is issued by NACE International under the auspices of STG 35.

<p>In NACE Standards, the terms <i>shall</i>, <i>must</i>, <i>should</i>, and <i>may</i> are used in accordance with the definitions of these terms in the NACE Publications Style Manual, 4th ed., Paragraph 7.4.1.9. <i>Shall</i> and <i>must</i> are used to state mandatory requirements. The term <i>should</i> is used to state something good and is recommended but is not mandatory. The term <i>may</i> is used to state something considered optional.</p>

**NACE International
Standard
Recommended Practice**

**Electrical Isolation of
Cathodically Protected Pipelines**

Contents

1. General..... 1
2. Need for Isolation 1
3. Methods of Isolation 1
4. Isolation from Other Metallic Structures 6
5. Selection of Isolation Device or Method..... 8
6. Equipment Specifications 8
7. Equipment Installation 11
8. Field Testing and Maintenance 13
References..... 16
Figures
Figure 1a: Full-Length Bolt Sleeves..... 2
Figure 1b: One-Half-Length Bolt Sleeves..... 2
Figure 2: Typical Isolating Monolithic Device 2
Figure 3: Typical Isolating Monolithic Joint..... 3
Figure 4: Typical Isolating Yoke-Type Device 3
Figure 5: Typical Isolating Union 4
Figure 6: Typical Isolating Spools..... 4
Figure 7: Typical Isolating Couplings..... 5
Figure 8: Typical Isolating Tapping Sleeve..... 5
Figure 9: Typical Casing/Sleeve Installation..... 6
Figure 10: Typical Use of Isolating Devices at Each End of a Bridge for a Cathodically
Protected Pipeline 7
Figure 11: Isolating Joint Test Station 11
Figure 12: Isolating Device Leakage Test 15

Section 1: General

1.1 This standard explains the importance of pipeline electrical isolation in achieving and maintaining adequate, reliable, and economical corrosion control. The standard outlines the types of devices used for isolation; precautions to be observed; and selection of devices based on pipeline characteristics, site, and contents. The standard describes isolating flanges, gaskets, sleeves, washers, joints, unions, couplings, and spools, and discusses materials for pipeline casing isolation. Installation, field testing, and maintenance of isolating devices are also included.

1.2 This standard describes the application of isolating devices intended only for cathodic protection purposes when voltages across the isolating device are 1 to 2 volts direct current (DC) and the alternating current (AC)

exposure does not exceed 15 volts root mean square (rms).³

1.3 This standard does not discuss situations in which isolating devices are incorporated purely for safety reasons; in those situations, reference should be made to relevant electrical safety codes. Isolating devices shall not be used in enclosed areas where combustible atmospheres are likely to be present.

1.4 Isolation of cathodically protected pipelines is recommended to minimize current requirements, facilitate testing and troubleshooting, and improve current distribution.

Section 2: Need for Isolation

2.1 Cathodic protection current intended for a given pipeline can flow to other underground facilities or equipment electrically connected to the pipeline. If protection of the other underground facilities is not intended, significant cathodic protection current can be lost unless preventive measures are taken. Generally called a current drain, this current loss can be reduced through electrical isolation of the pipeline.

2.2 Cathodic protection even of well-coated pipelines may not be economical or practical unless electrical isolation is achieved.

2.3 Pipeline casings should be electrically isolated from the carrier pipe.

2.4 If a pipeline passes through the wall of a valve pit or a building, metallic contact can occur between the pipe and the steel reinforcement in the concrete, causing a significant loss of protective current.

2.5 Electrical isolation can minimize or eliminate galvanic corrosion caused by dissimilar metals in contact with each other or caused by similar metals in contact with each other

when one metal is bare or has a dielectric coating system while the other has a permeable (e.g., concrete or mortar) coating system.

2.6 If a pipeline is designed to be electrically continuous but is supported by another metallic structure in contact with soil or groundwater, the pipeline should be isolated from that structure. The isolating supports must prevent damage to the pipeline coating and must accommodate relative movement, vibrations, and temperature differentials.

2.7 Isolation of power and instrumentation grounding systems may be required when electrically operated valves and similar components form part of a pipeline system. All applicable safety codes and standards must be followed.

2.8 If a pipeline is to be protected by more than one type of cathodic protection system, isolation of one or more sections may be desirable.

2.9 Isolation of pipelines can be beneficial in controlling or limiting the effect of stray currents such as telluric currents, currents associated with an electric traction system, or currents from nearby structures under cathodic protection.

Section 3: Methods of Isolation

3.1 Electrically isolating devices may be specially manufactured or prefabricated. It may be possible for existing fittings to be retrofitted with isolating materials to serve as isolating devices. Selection of the type of isolating device depends on the mechanical forces due to its position in the system, the operating temperature range, pressure constraints, and other considerations. Provisions should be

made for the connection of test wires for testing these isolating devices.

3.2 Flanges

3.2.1 A bolted pair of pipeline flanges may be converted into an electrically isolating device by

inserting an isolating gasket between the flanges and isolating sleeves over the shanks of the bolts, and placing isolating washers under the external steel washers to isolate the bolts (see Figures 1a and 1b). Isolating gaskets may have diameters equal to or greater than the outside diameter of the flanges, or they may fit within the bolt circle of the flange faces or into the groove of ring-type joint flanges. Isolating sleeves (around bolts) and washers (over bolts and under nuts and bolt heads) may also be combined as one-piece units. In some underground applications, the nuts and bolts may be isolated from one flange only so that cathodic protection will also protect all bolts and nuts. In some applications, isolating flanges are required to be pressure tested after assembly. When isolating flanges are being considered for use below ground, special consideration should be given to the installation (see Paragraph 7.2.5). If circumstances indicate that this type of installation would not be effective, an alternative device should be used.

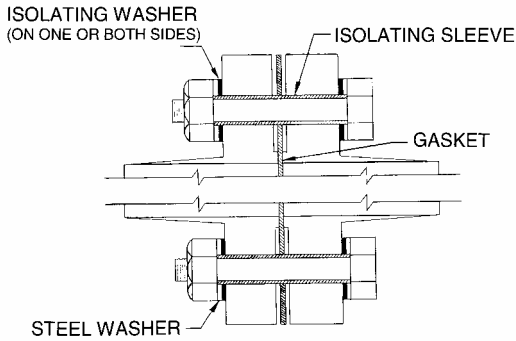

FIGURE 1a:
Full-Length Bolt Sleeves
 This figure shows the use of full-length bolt sleeves.

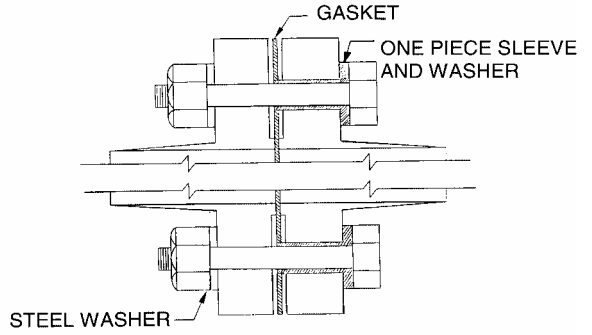

FIGURE 1b:
One-Half-Length Bolt Sleeves
 This figure shows the use of one-half-length bolt sleeves.

3.3 Prefabricated Isolating Joints

3.3.1 Pressure and electrical test certificates should be provided with any specially manufactured isolating joints. Unless the isolating device is pressure tested as part of the pipeline system, a pressure test certificate may be required in order to comply with applicable codes. These codes include Parts 192 and 195 of U.S. Department of Transportation⁽¹⁾ Regulations,⁴ ANSI⁽²⁾ B31.3,⁵ ANSI B31.4,⁶ and ANSI B31.8.⁷

3.3.2 Isolating monolithic joints for pressure services over 1,000 kPa⁽³⁾ (150 psi) (see Figure 2) consist of a pair of hubs on short pipe lengths; one hub is extended at its periphery by a barrel that overlaps the other hub. The two sections are aligned with the isolating materials and held in position with a large compressive force that is locked by welding, wedging, or swaging and is pressure-sealed. These units do not include any threaded components and cannot be disassembled on site.

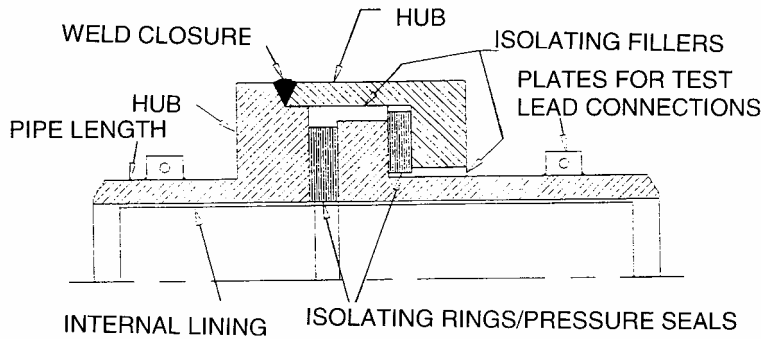

FIGURE 2:
Typical Isolating Monolithic Device
 High Pressure—Over 1,000 kPa (150 psi)

⁽¹⁾ U.S. Department of Transportation (DOT), 400 7th St. SW, Washington DC 20590.
⁽²⁾ American National Standards Institute (ANSI), 11 West 42nd St., New York, NY 10036.
⁽³⁾ 1 kPa = 0.01 bar.

3.3.3 Isolating monolithic joints for pressure services below 1,000 kPa (150 psi) are generally one of two types. One type consists of short lengths of pipe. The end of one length is enlarged and its internal surface serrated. An isolating sleeve bonded to the external

serrated surface of the other pipe fits into the enlarged pipe, which is swaged to hold the assembly in position. The second type (see Figure 3) is similar to the higher-pressure joint described in Paragraph 3.3.2.

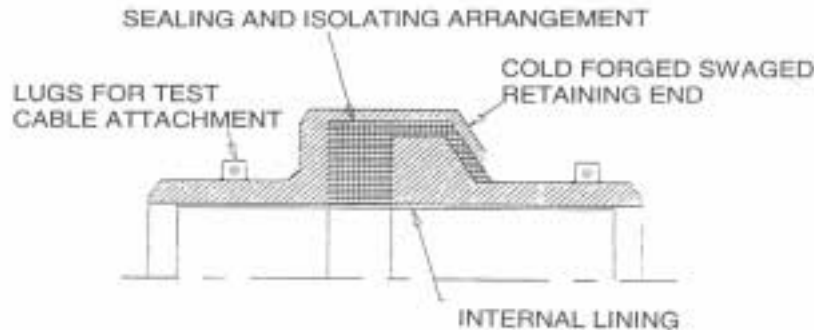

FIGURE 3:
Typical Isolating Monolithic Joint
 Pressure Service—Below 1,000 kPa (150 psi)
 (Other methods of construction are available.)

3.3.4 Isolating yoke-type joints (see Figure 4) include two hub assemblies. The back of one hub is conical. The two hubs are sealed using O-rings and isolating rings or spacers. The hubs are held together under pressure by an encircling yoke clamped by bolts through lugs that are normally tack welded.

3.4 Unions (see Figure 5)

An isolating union consists of two flanged bodies screwed onto the end of each connecting pipe. One flanged end is externally threaded, and the joint is held in position by a nut that is electrically isolated from the other end. The pressure seal may be achieved by using a molded seal and/or a gasket between mating faces.

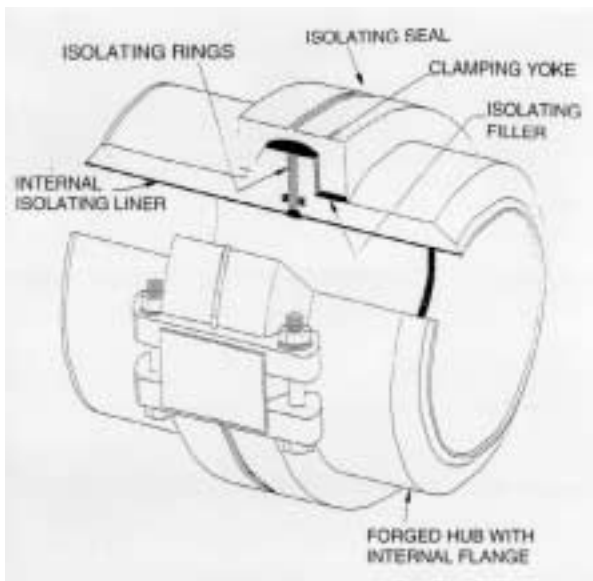

FIGURE 4:
Typical Isolating Yoke-Type Device

3.3.5 Prefabricated isolating flanges are factory-assembled isolating devices that are welded to a short pipe length with welded or screwed end preparations.

3.5 Spools (see Figure 6)

An isolating spool for pipelines carrying fluids may be made either by inserting a long piece of nonmetallic pipe into a piping system or by inserting a long piece of metallic pipe into the pipeline in combination with one or two of the devices described in Paragraphs 3.2 through 3.6. One of the isolating devices described in those paragraphs may also be used with an extended pipe length that has a high-electrical-resistance lining bonded to the isolating flange or joint and to the inside of the extended pipe length. When using this design, the extended length should also be the protected length.

3.6 Couplings (see Figure 7)

3.6.1 Bolted couplings consist of a cylindrical steel middle ring, two resilient gaskets, and steel follower rings connected by a set of steel trackhead bolts. Isolation may be provided by an isolating gasket under one of the follower rings and an isolating sleeve for one pipe end.

3.6.2 Screwed couplings consist of a forged steel or malleable iron body, an isolating gasket, two retainer cups, and two end nuts, with a combined isolating sleeve and end spacer provided for one pipe end.

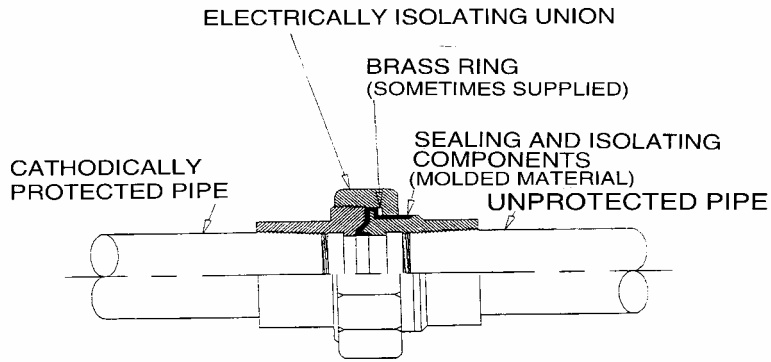

FIGURE 5:
Typical Isolating Union

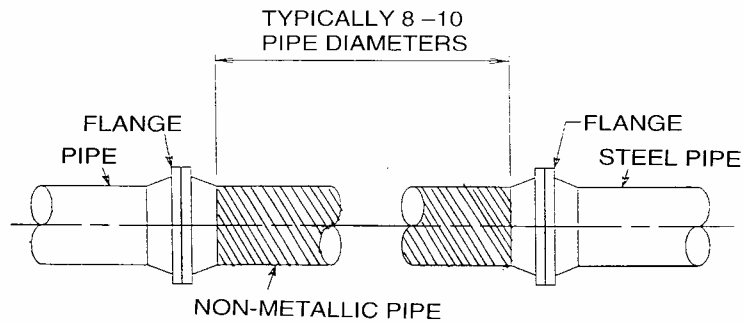
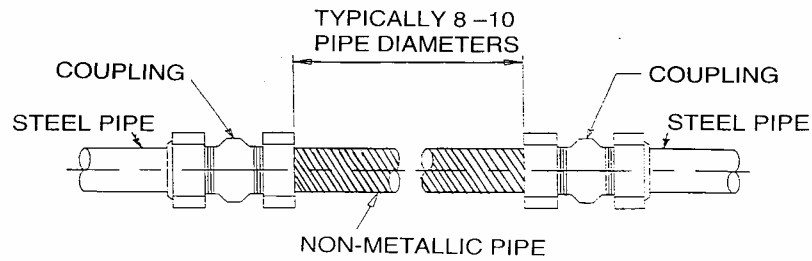

FIGURE 6:
Typical Isolating Spools

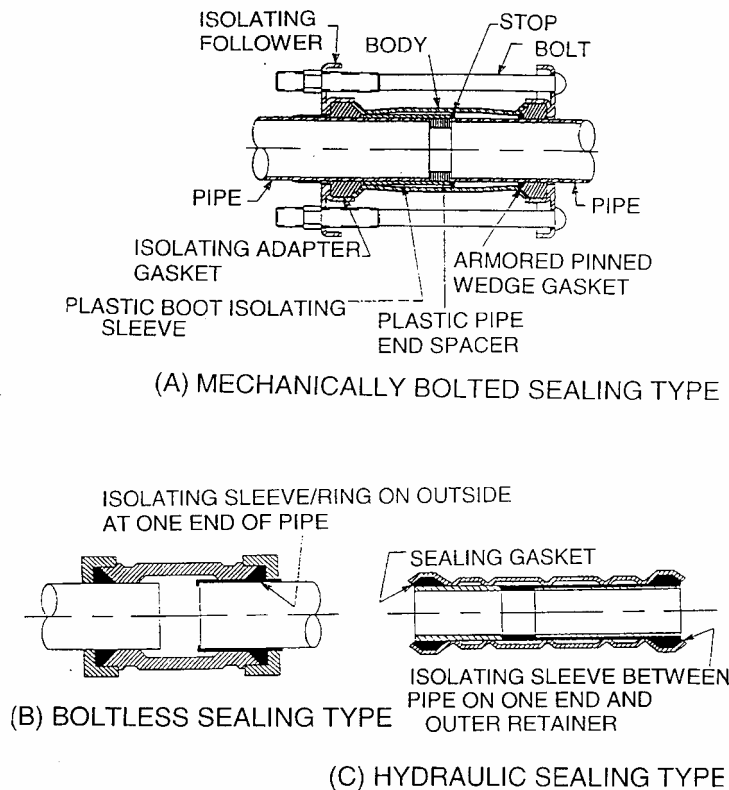

FIGURE 7:
Typical Isolating Couplings

3.6.3 A sleeved coupling with a hydraulic sealing system consists of a steel sleeve inside a pipe coupling with two isolating gaskets sealed by internal and external hydraulic pressure to the sleeve. The sleeve is equipped with an isolating gasket, an isolating sleeve, and an isolating pipe spacer.

3.7 Isolating Tapping Sleeve (see Figure 8)

3.7.1 An isolating tapping sleeve consists of a split sleeve installed over a pipe with the two halves connected by bolts and gaskets. One end of the fitting is equipped with isolating material.

3.8 Isolating Transition Fittings

3.8.1 Isolating transition fittings include a dielectric pipe fitting or a section of pipe or tubing that may be inserted in low-pressure pipeline systems.

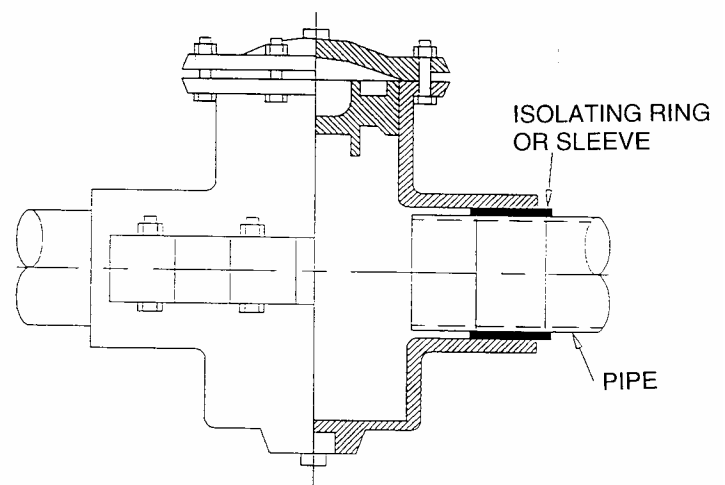

FIGURE 8:
Typical Isolating Tapping Sleeve

Section 4: Isolation from Other Metallic Structures

4.1 Pipelines to be cathodically protected must be isolated from other metallic structures unless the cathodic protection system has incorporated sufficient current drain for other metallic structures.

Isolation is provided by isolating spacers located circumferentially around the pipe. After these isolators are placed at intervals along the carrier pipe, the pipe is inserted into the casing (see Figure 9). NOTE: Other methods, such as coating pipes with concrete, are also used for isolation. The effectiveness of methods other than isolating spacers should be evaluated on a case-by-case basis.

4.1.1 Casings

4.1.1.1 Pipelines are commonly routed under roads and railways in steel casings. The casings are normally electrically isolated from the pipeline.

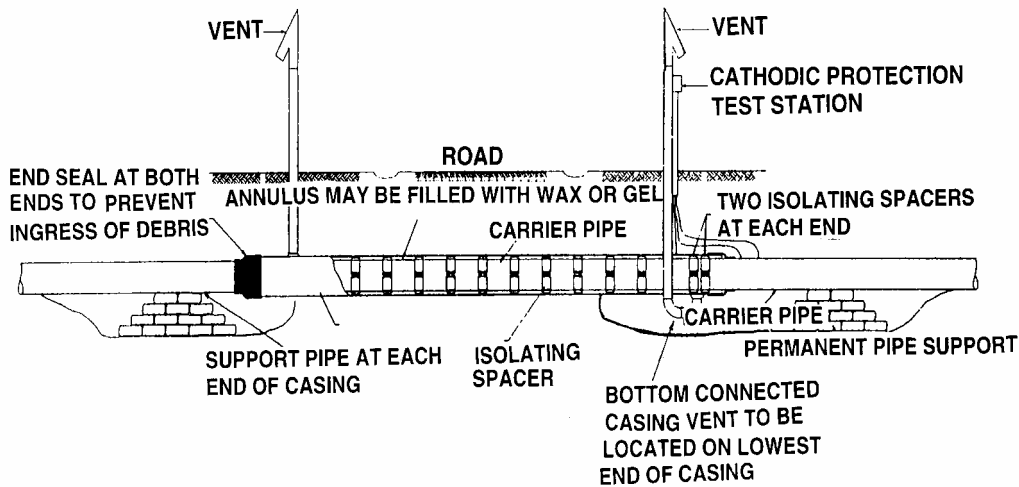

**FIGURE 9:
Typical Casing/Sleeve Installation**

4.1.1.2 Electrical isolation of the casing and carrier pipe provided by the isolating spacers may be relied on only as long as the carrier pipe remains physically separated from the casing pipe. Isolating spacers should be designed and spaced to withstand the loads caused by the movement of the carrier pipe under operational conditions.

electrically from the support cradles. Plastics, neoprene, fiberglass-reinforced plastic, or glazed ceramics may be used for these pads. The material chosen should be the most suitable for the pipeline service and environmental conditions.

4.1.1.3 The use of proper end-sealing and casing-filling methods can prevent possible contacts as well as the ingress of foreign substances.

4.1.2.2 If the cathodic protection system is designed so that the portion of the pipeline on the pipe bridge is isolated from the underground portion of the pipeline, a jumper wire can be bonded to the pipeline at the isolating device (see Figure 10) to provide electrical continuity around the isolated section on the bridge. The jumper wire must be sized to conduct the required cathodic protection current.

4.1.2 Pipe Bridges

4.1.2.1 Pipeline supports on a metallic pipe bridge shall be provided with pads to isolate the pipe

IN ADDITION OR ALTERNATIVELY, PIPELINE ON BRIDGE MAY BE SUPPORTED BY ISOLATING DEVICES WHICH ENSURE NO METALLIC CONTACT CAN OCCUR BETWEEN THE PIPELINE AND THE BRIDGE STRUCTURE.

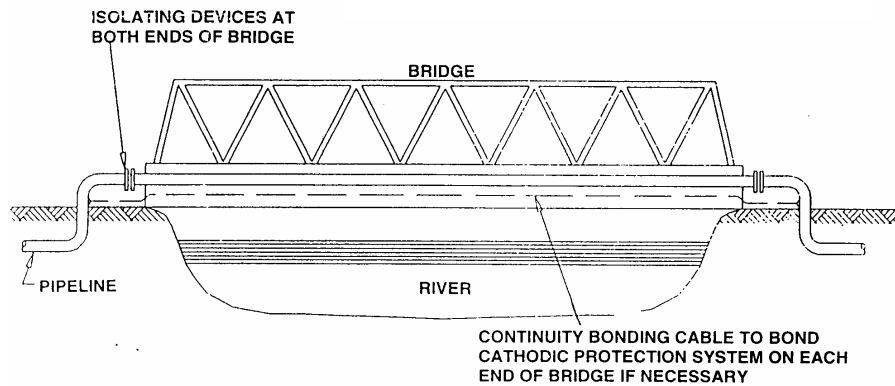

FIGURE 10:
Typical Use of Isolating Devices at Each End of a Bridge for a Cathodically Protected Pipeline

4.1.3 Pipeline Crossings

4.1.3.1 A minimum separation of 0.3 m (12 in.) should be maintained between all buried metallic structures at pipeline crossings. When this is not possible, consideration should be given to installation of isolating materials between the structures.

4.1.4 Offshore Platform Riser Pipes

4.1.4.1 Pipelines rising from the ocean bed onto offshore platforms may require electrical isolation from the structure's steel jacket, support legs, or, in the case of concrete platforms, the concrete-reinforcing steel. If the riser support is designed to allow movement of the riser pipe, then roller guides, flexible collars, or other suitable parts made of isolating materials can be used to ensure effective electrical isolation.

4.1.5 Electrical Grounds and Supply Cable Sheathing

4.1.5.1 Installation of electric motorized valves and instrumentation transducers in a pipeline connects the pipeline with the electrical supply earth grounding. Electrical isolation can be

obtained by using one of the following methods. Any measure taken should not conflict with applicable electrical codes.

4.1.5.1.1 Install a continuity bond cable around the assembly; then provide isolating joints on each side of the valve.

4.1.5.1.2 Ground the valve with appropriate devices; then isolate the electrical supply earth grounding from the valve.

4.1.5.1.3 Separately ground and connect the secondary side of the circuit to approved isolating equipment; then isolate the electrical supply earth grounding from the motor by terminating the supply on an isolating transformer or equipment approved for that application.

4.1.5.1.4 Ground separately, if necessary; then isolate the instrumentation transducer screen from the transducer.

4.1.5.1.5 Connect an approved electrical equipment device; then connect the electrical supply earth grounding by that means.

Section 5: Selection of Isolation Device or Method

5.1 The following factors should be carefully considered when selecting the isolating device or method to be used in any particular application.

- 5.1.1 Pipeline contents;
- 5.1.2 Pipeline temperature;
- 5.1.3 Pipeline pressure rating;

- 5.1.4 Location and orientation of isolating devices;
- 5.1.5 Piping configuration;
- 5.1.6 Isolation from foreign contact;
- 5.1.7 Necessity for field repair; and
- 5.1.8 Tensile, compression, and bending load requirements of the isolating devices.

Section 6: Equipment Specifications

6.1 This section defines the general requirements for materials for isolating devices and for the design and testing of isolating devices.

6.2 Isolating Flanges

6.2.1 Specifications—Material, design, manufacturing, testing, and marking specifications shall be agreed on by the customer and the vendor and shall be based on recognized standards.

6.2.2 Procurement Information—The following information is normally required for purchasing:

- 6.2.2.1 Pipe nominal diameter and material;
- 6.2.2.2 Flange standard;
- 6.2.2.3 Pressure class;
- 6.2.2.4 Product carried;
- 6.2.2.5 Operating temperature range;
- 6.2.2.6 Wall thickness of pipe;
- 6.2.2.7 Flange dimensions, pitch circle diameter, bolt size, number of bolts, etc., if nonstandard;
- 6.2.2.8 Flange face details (e.g., raised or full face, ring joint);
- 6.2.2.9 Test requirements; and
- 6.2.2.10 Isolating materials.

6.2.3 Design

6.2.3.1 Gaskets may either be full face or may fit inside the bolt circle. They should be a minimum of 3.0 mm (120 mils) thick and may protrude into

the bore of the pipe by 1.5 mm (60 mils) to prevent electrically conductive bridging over the isolation material. Thinner gaskets may be appropriate to reduce blowout potential.

6.2.3.2 Isolating bolt sleeves are normally designed for standard bolting in standard bolt holes and should be of sufficient length to extend halfway inside the steel washer. Care should be taken to ensure that the dimensions selected will allow the use of the standard-size bolt.

6.2.3.3 Isolating bolt washers should be sized internally to accommodate the bolt sleeve, and the OD should be sized so that the washer will fit inside the flange spot facing.

6.2.3.4 Steel washers should be the same size as the isolating washer and should be treated to prevent corrosion.

6.2.3.5 A combined isolating sleeve/isolating washer may be used.

6.2.4 Materials

6.2.4.1 Gaskets should be manufactured from isolating material having low cold-flow characteristics, low water absorption, and high compressive strength. Preference should be given to materials with low *y* and *m* factors. The *y* factor is a measure of the compressive load required to establish an initial seal, while the *m* factor is an indication of the additional load required to hold the fluid pressure needed to keep the seal in operation. The smaller these factors are, the less pressure is required to establish and maintain the seal. (The *m* and *y* factors for various materials are included in the ASME⁽⁴⁾ Boiler and Pressure Vessel Code, Section 8,⁸ ANSI B16.5,⁹ and BS⁽⁵⁾ 1560.¹⁰) For pipelines carrying water or water-

containing fluids, gaskets may consist of a laminate core material faced with a suitable sealing material (e.g., neoprene-faced phenolic), or with seals set into the laminate core material. For cryogenics, the core should be a suitable epoxy with either polytetrafluoroethylene (PTFE) or fluorinated ethylene propylene (FEP) seals, depending on the product and temperature. For high-pressure, high-temperature steam, gasket manufacturers should be consulted. For pipelines carrying hydrocarbons and other fluids, the gasket selected should be suitable for the particular application (product, pressure, temperature, etc.). Gaskets should have the highest compressive strength suitable for the service conditions.

6.2.4.2 Isolating bolt sleeves should be manufactured from materials having low water absorption (because of the limitations on thickness), high dielectric strength, and low cold-flow characteristics. They should be suitable for the service conditions of the particular application.

6.2.4.3 Isolating washers should be manufactured from materials having high compressive strength, low water absorption, high dielectric strength, and low cold-flow characteristics.

6.2.4.4 All materials should be selected to suit the operating conditions (product, pressure, temperature, etc.). Special consideration should be given to ensuring that the materials selected for the isolating sleeves and washers are not damaged during tightening at the time of installation.

6.2.5 Testing—The materials used should be supplied with suitable test certificates, if required, stating the compressive strength, *m* and *y* factors, temperature rating, pressure rating, water absorption, and dielectric strength.

6.3 Other Devices

6.3.1 Specifications—Material, design, manufacturing, testing, and marking generally shall be based on recognized standards.

6.3.2 Procurement Information—The following information is normally required for purchasing:

6.3.2.1 Pressure class;

6.3.2.2 Service temperature range;

6.3.2.3 Product carried;

6.3.2.4 Grade of pipe material;

6.3.2.5 Pipe dimensions;

6.3.2.6 Mandatory design standards and any unusual or high external forces (e.g., tension, bending, torsion, or thermal forces);

6.3.2.7 Internal and external coating;

6.3.2.8 Overall length of device;

6.3.2.9 Test/inspection requirements; and

6.3.2.10 Packing requirements.

6.3.3 Design

6.3.3.1 The design shall be such that under maximum working conditions, stress in any part of the device shall not exceed the specified minimum yield strength of that part.

6.3.3.2 The procedures used by manufacturers in final assembly shall ensure that the joint sealing does not allow leakage and that the joint seal is not damaged during fabrication or by testing conditions. Elastomer seals shall have permanent residual elasticity to ensure leak tightness.

6.3.4 Manufacture

6.3.4.1 The manufacturer shall be responsible for the integrity of the manufacturing procedures and conformance to the specifications provided by the customer.

6.3.4.2 The following information may be required by the customer:

6.3.4.2.1 General arrangement drawing and material safety data sheets (MSDS);

6.3.4.2.2 Detailed drawings showing all parts with material identification and stress/design calculations;

6.3.4.2.3 Full details of the manufacturing procedure;

6.3.4.2.4 Fabrication details including welding and inspection procedures;

6.3.4.2.5 Installation and maintenance instructions; and

6.3.4.2.6 Material and test certification, etc.

⁽⁴⁾ ASME International (ASME), Three Park Ave., New York, NY 10016-5990.

⁽⁵⁾ British Standards Institution (BSI), 389 Ciswich High Rd, London W4 4AL, United Kingdom.

RP0286-2002

6.3.5 Testing—The acceptance criteria shall be set in accordance with the requirements of the customer and of applicable codes.

6.3.5.1 Prototype testing should be conducted to prove the integrity of the design and manufacturing procedures; alternatively, independently witnessed test data may be satisfactory. For most applications, the following tests are conducted:

6.3.5.1.1 Hydrostatic cyclic pressure test;

6.3.5.1.2 Hydrostatic pressure plus bending test;

6.3.5.1.3 Vacuum test, where appropriate; and

6.3.5.1.4 Torsional test.

6.3.5.2 Common acceptance tests to be conducted on each device are:

6.3.5.2.1 Hydrostatic pressure test;

6.3.5.2.2 Dielectric and resistance tests; and

6.3.5.2.3 Holiday test on coatings/linings.

6.3.6 Marking—Each device may be identified using marking methods approved by the customer. The information given to identify the device could be as follows:

6.3.6.1 Purchase order number;

6.3.6.2 Joint serial number;

6.3.6.3 Manufacturer's name;

6.3.6.4 Nominal diameter;

6.3.6.5 Specification number;

6.3.6.6 Maximum design pressure;

6.3.6.7 Test pressure; and

6.3.6.8 Temperature rating.

6.4 Casing Isolator Spacers and End Seals

6.4.1 All isolating materials must be selected for the long-term retention of their compressive strength, dielectric properties, and resistance to ambient conditions. The primary function of the casing isolator is to isolate electrically and support the carrier pipe in the casing and protect the pipeline coating. The carrier pipe should be fully supported within each end of the

casing and externally to the casing at either end (see Figure 9).

6.4.1.1 Specifications for the casing isolator should provide the following information:

6.4.1.1.1 Width and thickness of the casing isolator;

6.4.1.1.2 Coating specifications for metallic components;

6.4.1.1.3 Dielectric material composition, physical characteristics, and compressive strength;

6.4.1.1.4 Number and spacing of isolating segments of casing isolator;

6.4.1.1.5 Carrier pipe insulator inner liner isolating material and dimensions; and

6.4.1.1.6 Attachment hardware.

6.4.2 Procurement Information—The following information is normally required for purchasing:

6.4.2.1 Actual carrier pipe outside diameter, including coating;

6.4.2.2 Casing inside diameter;

6.4.2.3 Bell or flange diameter (if applicable);

6.4.2.4 Clearance desired between the outside diameter of the pipe, including any flange, bells, or protective coatings, and the casing inside diameter;

6.4.2.5 Position within casing (standard, centered, or restrained);

6.4.2.6 Casing length and the weight per linear meter (foot) of the carrier pipe;

6.4.2.7 Density of the fluid/product carried, and

6.4.2.8 Operating temperatures and environment.

6.4.3 Materials

6.4.3.1 The materials selected must be compatible with the carrier pipe coating, the environment, and all operating conditions. The thickness, spacing, and components of the casing isolator should be designed to prevent contact between the carrier pipe and the casing.

Section 7: Equipment Installation

7.1 This section discusses the procedures to be used when installing the equipment described in Section 3. The procedures are designed to ensure that:

7.1.1 A satisfactory degree of electrical isolation is achieved at the time of installation and that the joint is not damaged so as to cause an accelerated degradation rate with time;

7.1.2 The installed equipment is adequately protected against the effects of stray DC or induced AC voltages;

7.1.3 There is adequate provision for test wires to allow for field testing and maintenance (typical arrangements are shown in Figure 11); and

7.1.4 Electrical continuity is provided to all parts of bolted isolated couplings to ensure their inclusion in the cathodic protection system.

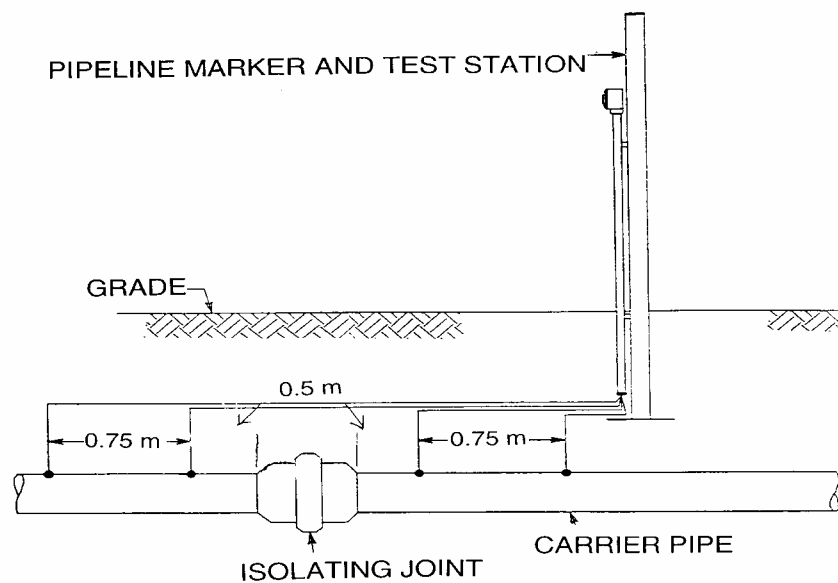

**FIGURE 11:
Isolating Joint Test Station**

7.2 Installation

7.2.1 General—When installed, all equipment items should be properly supported and aligned so that any forces transferred from the adjoining pipe are minimized. This should be considered when equipment locations are selected. The equipment chosen must be suitable for the mechanical forces to be encountered at the selected site. Isolating devices should not be installed in gas systems at locations where the accumulation of internal moisture is likely. When feasible, the flanges and isolating devices should be assembled and tested before and after installation.

7.2.2 Monolithic Isolating Devices (see Figures 2 and 3)

7.2.2.1 Monolithic isolating devices may be supplied in a form suitable for welded, flanged, or threaded ends.

7.2.2.2 Monolithic isolating devices for welding should be ordered with the weld end preparation conforming to the main pipe-laying specifications. The manufacturer's special installation instructions must always be followed, particularly when welding joints with short overall lengths, to ensure that the heat generated does not damage the isolating materials used in the joint construction.

7.2.3 Yoke-Type Isolating Joints (see Figure 4)—These joints should be installed as described in Paragraph 7.2.1. Particular care should be taken in supporting the yoke joint and adjacent pipe to ensure that minimum strain is applied during welding and backfilling.

7.2.4 Isolating Spools (see Figure 6)—These joints must be installed as described in Paragraph 7.2.1. In the case of linings, additional care should be taken to ensure that the direction of the joint is correct. The side of the joint that has the longer length of internal lining must be attached to the protected side of the pipeline. Linings must be fused or bonded to the internal surface of the pipe.

7.2.5 Isolating Flange Joints (see Figures 1a and 1b)

7.2.5.1 Factory Preassembled Joints—These are supplied with weld ends and should be installed as described in Paragraph 7.2.1.

7.2.5.2 Isolating Gasket Kits

7.2.5.2.1 Flanges are welded or screwed onto the pipeline, and the isolating gasket is supplied as a kit for on-site installation. Ideally, the installation should take place in clean, dry conditions. Flanges on which isolating gaskets are to be installed should be supplied as matched pairs or reamed on site to ensure correct alignment of bolt holes.

7.2.5.2.2 The flange faces should be clean and correctly aligned. Misaligned flanges will result in damage to the isolating sleeve during assembly or subsequent springing of the pipe. Flange faces should be square and free of burrs to allow for correct sealing of nuts, bolts, and washers.

7.2.5.2.3 The isolating gasket should be carefully aligned between the flange faces and the bolt holes. It may be easier to use one size smaller diameter, high-tensile-strength steel bolts, and/or special thin-walled sleeving to assist alignment.

7.2.5.2.4 Alignment pins should be inserted to ensure that flange alignment is maintained during installation of the isolating sleeves.

7.2.5.2.5 The isolating sleeves are then positioned in the correctly aligned holes. Isolating sleeves must be of the correct length. If they are too long, they may be damaged when the bolt nuts are finally tightened. If they are too short, they may fail to provide proper isolation. The length of the isolating sleeve shall normally include the two isolating washers, except where alignment allows only one flange to be isolated.

7.2.5.2.6 The bolts, complete with isolating washers adjacent to the flange and steel washers under the bolt and/or nut heads, are inserted through the sleeves and tightened by hand.

7.2.5.2.7 The original alignment pins may then be removed and bolts installed, complete with sleeves and washers as described above.

7.2.5.2.8 Final tightening to the tension recommended for the diameter and pressure rating of the flange shall be done in a sequence that provides for equal tension without distortion.

7.2.5.2.9 Before measures are taken to protect against the ingress of moisture, the effectiveness of the isolation achieved should be checked using appropriate methods.

7.2.5.3 Protection Against Ingress of External Moisture—The materials used for the isolating sleeves, washers, and gaskets may absorb water, and the construction of the joint may allow for moisture ingress, both of which reduce the electrical resistance of the assembly. Therefore, providing a protective coating is essential. A suitable material may be applied to fill in the crevices and gaps between flange faces and mold around the flange faces in underground installations. In this way, a smooth profile that may be coated or wrapped to the same standard as the pipeline, together with the adjacent pipe work, is achieved.

7.2.6 Pipeline Casing Isolators (see Figure 9)

7.2.6.1 Pipeline casing isolators must be installed in accordance with the manufacturer's instructions. Special care should be taken to ensure that all subcomponents are correctly assembled and tightened and that no damage occurs during insertion of the carrier pipe.

7.2.6.2 The annulus between the carrier pipe and the casing should be sealed at each end of the casing to prevent electrolyte, debris, and the surrounding soil from entering the casing.

7.2.6.3 There must be no metallic contact between the casing and the carrier pipe. The spacing of isolators should ensure that the carrier pipe is adequately supported throughout its length, particularly at the ends, to prevent settling and possible electrical shorting of the pipe and casing.

7.2.7 Pipeline Support Isolators—Care should be taken to ensure that isolating materials used in isolating supports are adequately secured so as to eliminate the possibility of dislodging, which would render the isolation ineffective.

7.3 High-Voltage Protection

7.3.1 Isolating devices and supports should be protected against damage from high-voltage surges. These surges may be caused by lightning, induced AC from adjacent or overhead high-voltage cables, fault conditions, power pipeline conditions, or switching surges (see NACE Standard RP0177²). If isolating joints exist in these corridors and must be maintained for cathodic protection design reasons, then they must be made conductive to AC currents by the use of capacitors, polarization cells, or any equivalent solid-state product. (See EPRI⁽⁶⁾ Report EL 904¹¹ for more information.) Protective devices (surge suppressors, lightning arresters, etc.) are usually designed for a specific purpose. Protective equipment must be selected and used in accordance with the intended purpose, following all manufacturer's specifications.

7.3.2 High-voltage surges may permanently damage the isolating materials used in the joint construction.

7.3.3 Isolating devices and supports may be protected with lightning arresters, electrolytic grounding cells, polarization cells, equivalent solid-state products, or combinations of these.

7.3.4 Electrical surges and fault currents of all types are potentially hazardous. Pipelines equipped with isolating devices may be protected from stray-current hazards originating from electrical power supplies through the use of grounding media and/or isolation protection equipment. Grounding media that should be considered for the discharge of induced AC, lightning, and fault current from a pipeline to earth include packaged galvanic anodes of magnesium or zinc and extruded ribbon of magnesium or zinc, with or without backfill. Electrically isolated bare steel pipeline casing, grounding grids, and ground rods should also be considered suitable grounds but must be separated from the cathodically protected pipeline by capacitors, zinc grounding cells, polarization cells, or equivalent solid-state products.

7.3.5 The manufacturer's instructions must be followed strictly when installing protective devices. In particular,

the devices shall be physically secured and the connection cables properly sized.

7.3.6 The threshold rating of the protective device must be such that, even allowing for tolerances, the potential applied across the isolating device is below the device's minimum dielectric strength.

7.3.7 Lightning arresters and other protective devices shall be located to prevent the collection of dirt and moisture, which could lead to an external flashover at a relatively low surge voltage. Applicable electrical codes shall be consulted. To prevent incendiary spark hazards at fuel-transfer facilities, electrical isolation shall be avoided in areas where a combustible atmosphere may exist.

7.4 Provision for Field Testing

7.4.1 Methods of testing the effectiveness of the electrical isolation are described in Section 8. The following paragraphs describe the provision of test wires to facilitate these measurements. Test wires on buried devices should be attached on both sides of any isolating device and on the carrier pipe and casing of sleeved systems.

7.4.2 Attachment of Test Wires

7.4.2.1 Test wires on buried isolating devices shall be installed in accordance with NACE Standard RP0169, Paragraphs 4.5 and 8.6.¹

7.4.2.2 Care should be taken when attaching test wires to prevent damage to the internal coating or lining by excessive heat.

7.4.3 Wire Type

7.4.3.1 The wire cross section and type of sheath insulation must be selected to take into account the location and expected (or future) current to be carried. Wires should be labeled for permanent identification.

Section 8: Field Testing and Maintenance

8.1 This section deals with the testing and maintenance of electrical isolation facilities. In testing the effectiveness of isolating devices installed on buried piping systems, the effect of pipe grounding and other equivalent electrical parallel circuit conditions that may exist must be considered.

Conventional ohmic resistance measurements, as applied to the total isolating device, are not conclusive under field conditions. However, ohmic resistance measurements may have validity in checking individual components of an isolating device.

⁽⁶⁾ Electric Power Research Institute (EPRI), 3412 Hillview Ave., Palo Alto, CA 94304-1395.

8.2 Field Testing

8.2.1 Several tests may be used to determine the effectiveness of an isolating device, depending on the following:

8.2.1.1 The experience and training of the staff conducting the tests;

8.2.1.2 The environment and location of the device; and

8.2.1.3 The local potential and magnitude of any cathodic or anodic electrical currents.

8.2.2 If the isolating device is installed and connected on both sides, a test may be conducted in which current is applied to the pipe on one side of the assembly and effectiveness is judged by the resulting difference in pipe-to-soil potentials measured on both sides of the device.

8.2.3 When desired, a test can be conducted to obtain the percent of leakage at an isolating device (see Figure 12). However, if the isolating device is located adjacent to a section of above-grade piping, a voltage-drop measurement can be readily taken to determine isolating effectiveness.

8.2.4 When the isolating device incorporates bolts that require full isolation from all other metal work (e.g., bolts used in an isolated flanged joint in which an isolating washer is used beneath each bolt head or nut), it may be possible to check for proper isolation of each bolt. This check has considerable validity because bolt isolation is normally the part of the assembly that is most susceptible to failure. The test should be conducted by using an ohmmeter or other device to prove isolation between each bolt or stud and the metal against which it is to be isolated.

8.2.5 For cathodically protected pipelines, a good indication of performance may be the change in protection level adjacent to the isolating device that occurs when the isolating device is deliberately shorted. The results from such a test depend on the

resistance to earth of the unprotected structure from which the protected pipeline is isolated. When this resistance to earth is very low, a significant reduction in the level of protection may be expected.

8.2.6 Audio-frequency pipe locators may indicate the effectiveness of isolating devices.

8.2.7 Radio-frequency meters may also indicate the effectiveness of isolating devices.

8.2.8 A magnetometer system may be used for testing the effectiveness of isolating devices.

8.3 Isolating Devices in Parallel—When a number of isolating devices are installed in parallel (e.g., several flanged joints at a manifold), IR drops or current measurements in each line may be the only method of proving effectiveness of an individual device. Techniques that measure magnetic fields in the flange area may also serve as an indication of the device's effectiveness. The use of audio-frequency and radio-frequency instruments may indicate the comparative effectiveness of each individual device.

8.4 Maintenance

8.4.1 Test stations and test wires attached at isolating devices should be subject to a regular maintenance program. Figure 11 shows the typical configuration of test stations.

8.4.2 Isolating devices that are aboveground and open to the weather should be inspected periodically and cleared of accumulated debris, which could bridge isolating material. Any protective barrier coatings provided to prevent water absorption by isolating materials should be kept in good condition. Paints, thermal barriers, and tracers and reinforcements with a metallic content such as aluminum or zinc should not be used as barrier coatings.

8.4.3 When the effectiveness of isolating devices is tested on site, the effectiveness of any high-voltage protection device should also be checked.

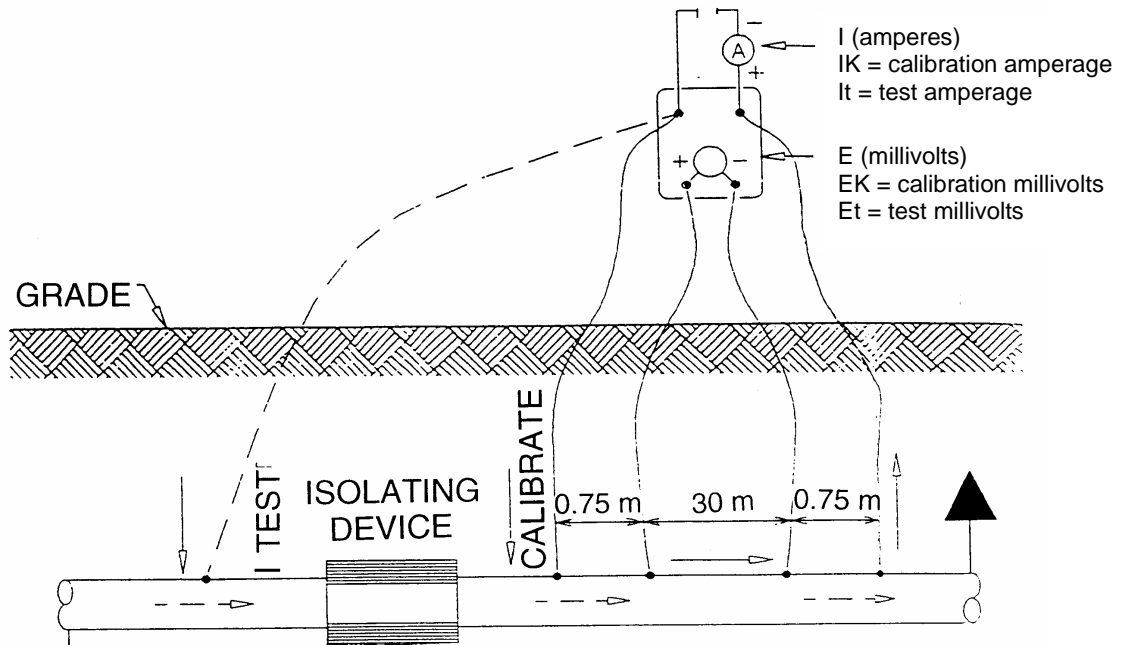

1. Calculate the calibration factor: $K = \Delta IK / \Delta EK = \text{Amps/mV}$
2. Calculate the percentage leakage: $\% \text{ leakage} = \frac{K \times \Delta Et \times 100}{It}$

Example: Given the following data:

Calibration: $IK = +6.42 \text{ Amps}$
 $EK = +3.55 \text{ mV}$

Test: $It = +1.61 \text{ Amps}$
 $\Delta Et = +0.14 \text{ mV}$

Calculate:

$$K = \frac{6.42 \text{ Amps}}{3.55 \text{ mV}} = 1.81 \text{ A/mV}$$

$$\begin{aligned} \% \text{ leakage} &= \frac{K \times \Delta Et \times 100}{It} \\ &= \frac{1.81 \text{ A/mV} \times 0.14 \text{ mV} \times 100}{1.61 \text{ Amps}} \\ &= 15.7\% \end{aligned}$$

FIGURE 12:
Isolating Device Leakage Test

References

1. NACE Standard RP0169 (latest revision), "Control of External Corrosion on Underground or Submerged Metallic Piping Systems" (Houston, TX: NACE International).
2. NACE Standard RP0177 (latest revision), "Mitigation of Alternating Current and Lightning Effects on Metallic Structures and Corrosion Control Systems" (Houston, TX: NACE).
3. CAN/CSA-C22.3 No. 6 (latest revision), "Principles and Practices of Electrical Coordination Between Pipelines and Electrical Supply Lines" (Rexdale, Ontario: Canadian Standards Association).
4. U.S. Code of Federal Regulations (CFR) Title 49, "Protection Against Accidental Overpressure," Parts 192 and 195 (Washington DC: Office of the Federal Register).
5. ANSI B31.3 (latest revision), "Chemical Plant and Petroleum Refinery Piping" (New York, NY: ASME).
6. ANSI B31.4 (latest revision), "Liquid Transportation Systems for Hydrocarbons, Liquid Petroleum Gas, Anhydrous Ammonia, and Alcohols" (New York, NY: ASME).
7. ANSI B31.8 (latest revision), "Gas Transmission and Distribution Piping Systems" (New York, NY: ASME).
8. ASME Boiler and Pressure Vessel Code, Section 8, "Rules for Construction of Pressure Vessels" (New York, NY: ASME).
9. ANSI B16.5 (latest revision), "Pipe Flanges and Flanged Fittings" (New York, NY: ASME).
10. BS 1560 (latest revision), "Steel Pipe Flanges and Flanged Fittings" (London: British Standards Institution).
11. EPRI Report EL 904, "Mutual Design Considerations for Overhead AC Transmission Lines and Gas Transmission Lines" (Palo Alto, CA: Electric Power Research Institute).